



Las Vegas, US
14th~18th, Mar, 2023



Hannover, DE
17th~21st, Apr, 2023

PTC ASIA

Shanghai, CN
24th~27th, Oct, 2023

automechanika
FRANKFURT

Frankfurt, DE
10th~14th, Sep, 2024

bauma CHINA

Shanghai, CN
26th~29th, Nov, 2024



液壓機械一站式採購基地
No.1 Global One-Stop Mall In Hydraulic Field

HYVA SERIES CYLINDER



台州永暢液壓機械有限公司
Taizhou Eternal Hydraulic Machine Co., Ltd.

Code system tipping cylinders

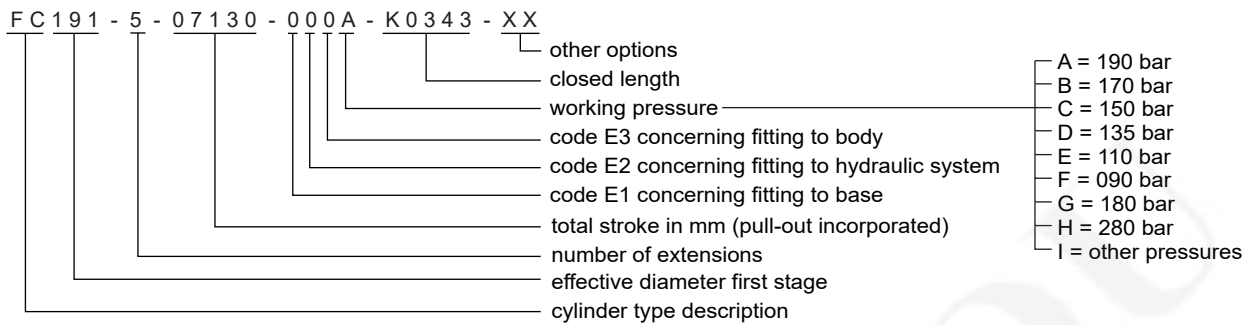

Cylinder type description

- FC - front-end cylinder with outer cover
- FCT - front-end cylinder with outer cover and bottom tank
- FE - front-end cylinder with piston eye
- FEE - front-end cylinder with piston eye and bottom eye
- UMB / UME - under body cylinder for three way tipping
- DA / DE - double acting cylinder
- KRM / KRA - under body cylinder for three way tipping

Code E1 concerning fitting to base

- 0 standard trunnion at standard position

Code E2 concerning fitting to hydraulics

- 0 standard inlet at standard front position
- 1 standard inlet at non-standard front position
- 7 standard inlet at side

Code E3 concerning fitting to body

- 0 standard cover
- 1 standard spherical eye
- 2 fixed eye with bush
- 4 non standard cover
- 8 fixed eye without bush
- 9 special cover or piston

Front-end cylinder kits

To simplify the choice of the right adapters and mounting equipment We offers tipping cylinder kits for chassis and cradle mounted cylinders. We have kits with straight or 90° connections for high pressure hose connections.

Code system cylinder kits

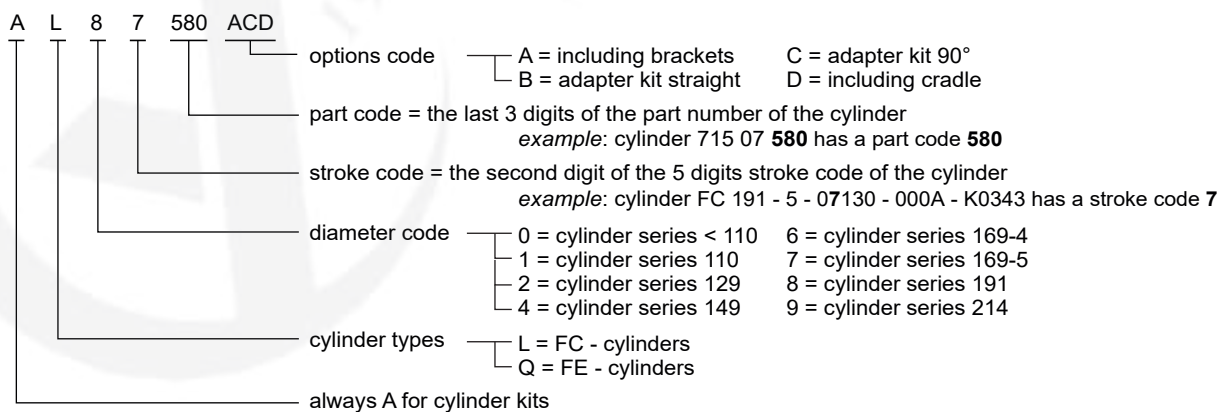

Kits for cylinders with the effective diameter of the first stage smaller or equal 149 mm are standard equipped with adapters for 3/4" high pressure hoses. Bigger cylinders have adapters for 1" high pressure hoses.

Carefully read mounting instructions before making a selection. Tipping program also assist you making the best and safest choice.

Always mind:

- ◆ Maximum fitting angle for closed cylinder (varies with cover length)
- ◆ Available free space on tipper
- ◆ Maximum angle for extended cylinder (29 degrees)

FC 077 front-end cylinder with outer cover

Part no.	Kit no.	Description	Press (bar)	Tipping weight (tons)	Weight (kg.)	Vol. (ltr.)	Inlet BSP	H* (mm)	J (mm)	K* (mm)
714 90 220	AI02207	FC 077-3-02900-000A-K0203	170	7 - 10	61	9	1/2"	1162	58	203
714 90 240	AI03220	FC 077-3-03200-000A-K0203	170	7 - 10	66	10	1/2"	1262	58	203

* incl. 20 mm pull out (p.o.); tolerances -5 +30

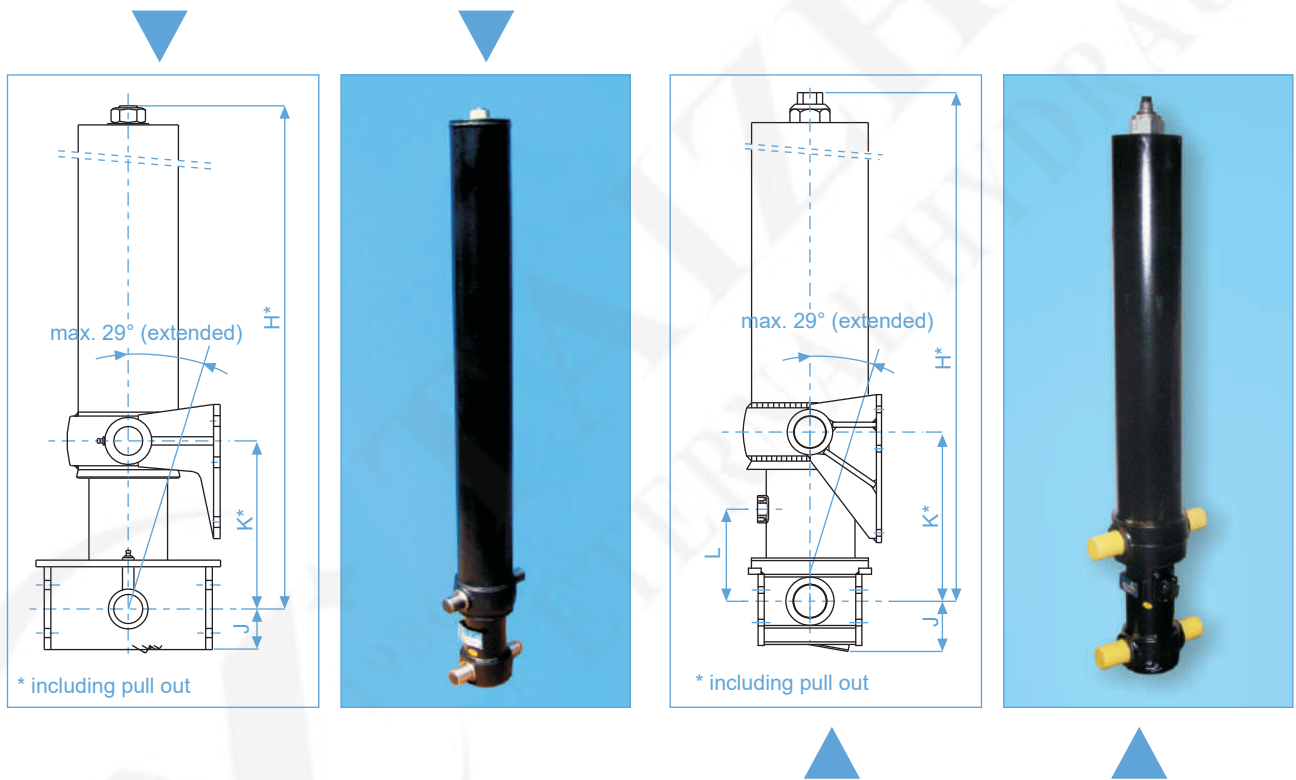

FC 091 & FC 093 front-end cylinders with outer cover

Part no.	Kit no.	Description	Press (bar)	Tipping weight (tons)	Weight (kg.)	Vol. (ltr.)	Oil inlet	H* (mm)	J (mm)	K* (mm)	L (mm)
715 02 160	AL03160	FC 091-3-03205-000A-K0298	190	11 - 20	123	16	1"SAE	1464	81	298	160
715 02 180	AL03180	FC 091-3-03460-000A-K0298	190	11 - 18	129	17	1"SAE	1549	81	298	160
714 91 240	AI04220	FC 093-3-03245-001B-K0343	170	13 - 17	95	18	1"SAE	1307	81	343	190
714 91 260	AI04240	FC 093-3-03470-001B-K0343	170	13 - 16	99	19	1"SAE	1382	81	343	190

* incl. 20 mm pull out (p.o.); tolerances -5 +30

FC 110 front-end cylinders with outer cover

Part no.	Kit no.	Description	Press (bar)	Tipping weight (tons)	Weight (Kg.)	Vol. (ltr.)	Oil inlet	H* (mm)	J (mm)	K* (mm)	L (mm)
715 03 160	AL13160	FC 110-3-03205-000A-K0343	190	21 - 51	128	24	1"SAE	1399	86	343	190
715 03 180	AL13180	FC 110-3-03460-000A-K0343	190	21 - 44	135	26	1"SAE	1484	86	343	190

* incl. 20 mm pull out (p.o.); tolerances -5 +30

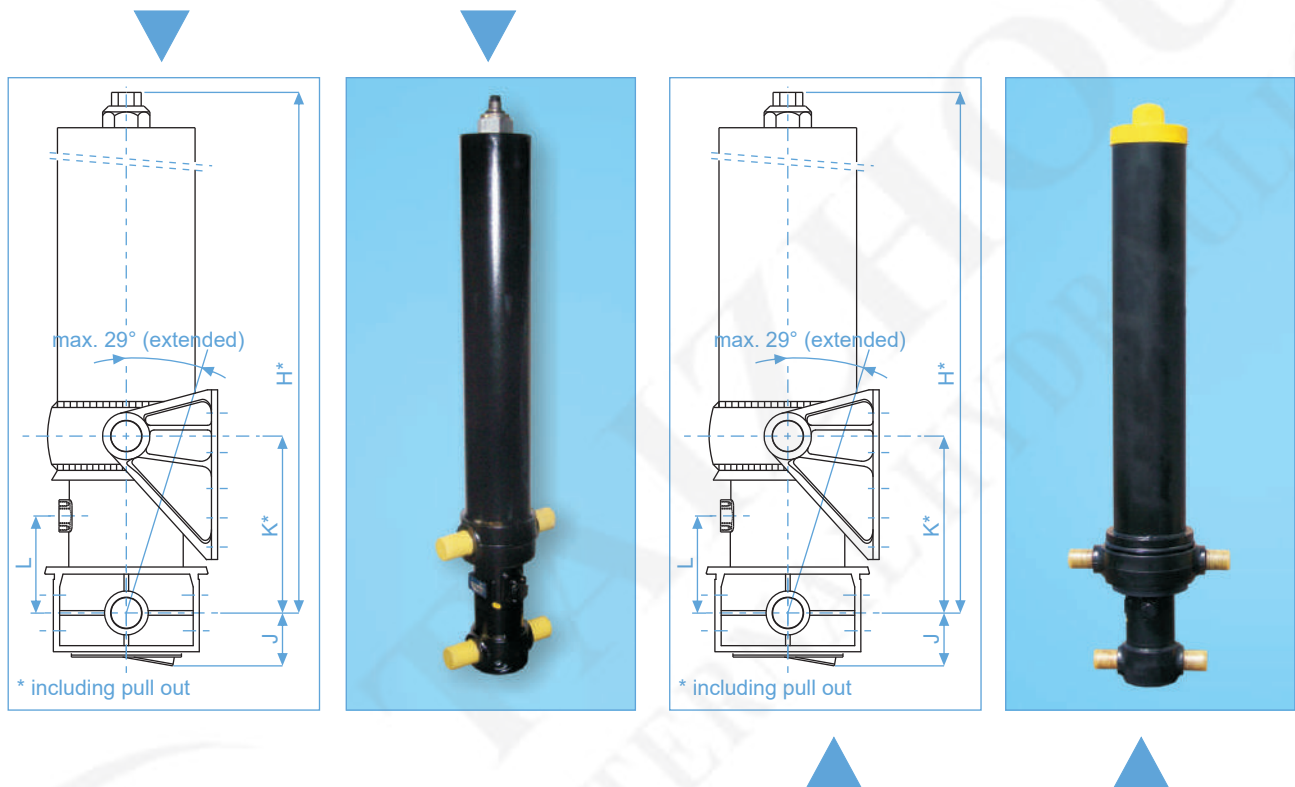

FC 129 front-end cylinders with outer cover

Part no.	Kit no.	Description	Press (bar)	Tipping weight (tons)	Weight (kg.)	Vol. (ltr.)	Oil inlet	H* (mm)	J (mm)	K* (mm)	L (mm)
715 04 180	AL23180	FC 129-3-03460-000A-K0343	190	34 - 58	198	37	1"SAE	1484	91	343	190
715 04 220	AL23220	FC 129-3-03880-000A-K0343	190	33 - 54	215	42	1"SAE	1634	91	343	190
715 04 250	AL24250	FC 129-3-04270-000A-K0343	190	34 - 62	229	46	1"SAE	1764	91	343	190
715 04 262	AL24262	FC 129-4-04280-070A-K0343	190	22 - 54	202	40	1"SAE	1399	91	343	190
715 04 290	AL24290	FC 129-4-04620-000A-K0343	190	22 - 50	212	43	1"SAE	1474	91	343	190
715 04 392	AL25392	FC 129-4-05180-070A-K0343	190	22 - 41	231	48	1"SAE	1644	91	343	190

* incl. 20 mm pull out (p.o.); tolerances -5 +30

FC 149, 169 & 191 front-end cylinders with outer cover

Part no.	Kit no.	Description	Press (bar)	Tipping weight (tons)	Weight (kg.)	Vol. (ltr.)	Oil inlet	H* (mm)	J (mm)	K* (mm)	L (mm)
715 05 220	AL43220	FC 149-3-03880-000A-K0343	190	48 - 71	250	56	1"SAE	1644	96	343	190
715 05 256	AL44256	FC 149-3-04270-000A-K0343	190	50 - 73	266	62	1"SAE	1774	96	343	190
715 05 262	AL44262	FC 149-4-04280-070A-K0343	190	36 - 73	236	55	1"SAE	1399	96	343	190
715 05 292	AL44292	FC 149-4-04620-070A-K0343	190	36 - 68	247	59	1"SAE	1474	96	343	190
715 05 354	AL44354	FC 149-4-04940-000A-K0343	190	35 - 74	259	63	1"SAE	1554	96	343	190
715 05 404	AL45404	FC 149-4-05180-070A-K0343	190	34 - 68	270	66	1"SAE	1634	96	343	190
715 05 422	AL45422	FC 149-4-05460-070A-K0343	190	34 - 64	280	69	1"SAE	1714	96	343	190
715 06 260	AL64260	FC 169-4-04280-000A-K0343	190	53 - 81	268	73	1"SAE	1394	106	343	190
715 06 290	AL64290	FC 169-4-04620-000A-K0343	190	52 - 82	282	78	1"SAE	1479	106	343	190
715 06 320	AL64320	FC 169-4-04940-000A-K0343	190	51 - 79	295	84	1"SAE	1559	106	343	190
715 06 390	AL65390	FC 169-4-05180-000A-K0343	190	51 - 84	310	87	1"SAE	1629	106	343	190
715 06 410	AL75410	FC 169-5-05355-000A-K0343	190	35 - 74	285	80	1"SAE	1384	106	343	190
715 06 430	AL65430	FC 169-4-05460-000A-K0343	190	50 - 81	319	92	1"SAE	1699	106	343	190
715 06 440	AL65440	FC 169-4-05700-000A-K0343	190	49 - 77	329	96	1"SAE	1769	106	343	190
715 06 450	AL75450	FC 169-5-05780-000A-K0343	190	35 - 66	300	87	1"SAE	1469	106	343	190
715 06 490	AL76490	FC 169-5-06180-000A-K0343	190	34 - 62	314	93	1"SAE	1549	106	343	190
715 06 550	AL76550	FC 169-5-06830-000A-K0343	190	34 - 57	340	102	1"SAE	1709	106	343	190
715 06 580	AL77580	FC 169-5-07130-000A-K0343	190	34 - 50	351	107	1"SAE	1759	106	343	190
715 06 678	AL77678	FC 169-5-07630-004A-K0343	190	33 - 47	373	114	1"SAE	1889	106	343	190
715 06 720	AL78720	FC 169-5-08130-000A-K0486	190	33 - 46	387	122	1"SAE	1989	106	486	190
715 06 860	AL79860	FC 169-5-09030-000C-K0486	150	26 - 35	424	135	1"SAE	2209	106	486	190
715 06 910	AL79910	FC 169-5-09530-000D-K0486	135	23 - 30	441	143	1"SAE	2309	106	486	190
715 07 424	AL85424	FC 191-4-05460-000A-K0343	190	68 - 90	381	120	1"SAE	1712	116	343	190
715 07 452	AL85452	FC 191-5-05780-000A-K0343	190	51 - 83	358	114	1"SAE	1482	116	343	190
715 07 490	AL86490	FC 191-5-06180-000A-K0343	190	59 - 79	375	122	1"SAE	1562	116	343	190
715 07 580	AL87580	FC 191-5-07130-000A-K0343	190	49 - 72	420	140	1"SAE	1772	116	343	190
715 07 680	AL87680	FC 191-5-07630-004A-K0343	190	49 - 69	447	150	1"SAE	1902	116	343	190
715 07 720	AL88720	FC 191-5-08130-000A-K0486	190	48 - 67	463	160	1"SAE	2002	116	343	190
715 07 860	AL89860	FC 191-5-09030-000B-K0486	170	43 - 57	508	177	1"SAE	2212	116	486	190
715 07 910	AL89910	FC 191-5-09530-000C-K0486	150	37 - 49	529	187	1"SAE	2312	116	486	190

* incl. 20 mm pull out (p.o.); tolerances -5 +30

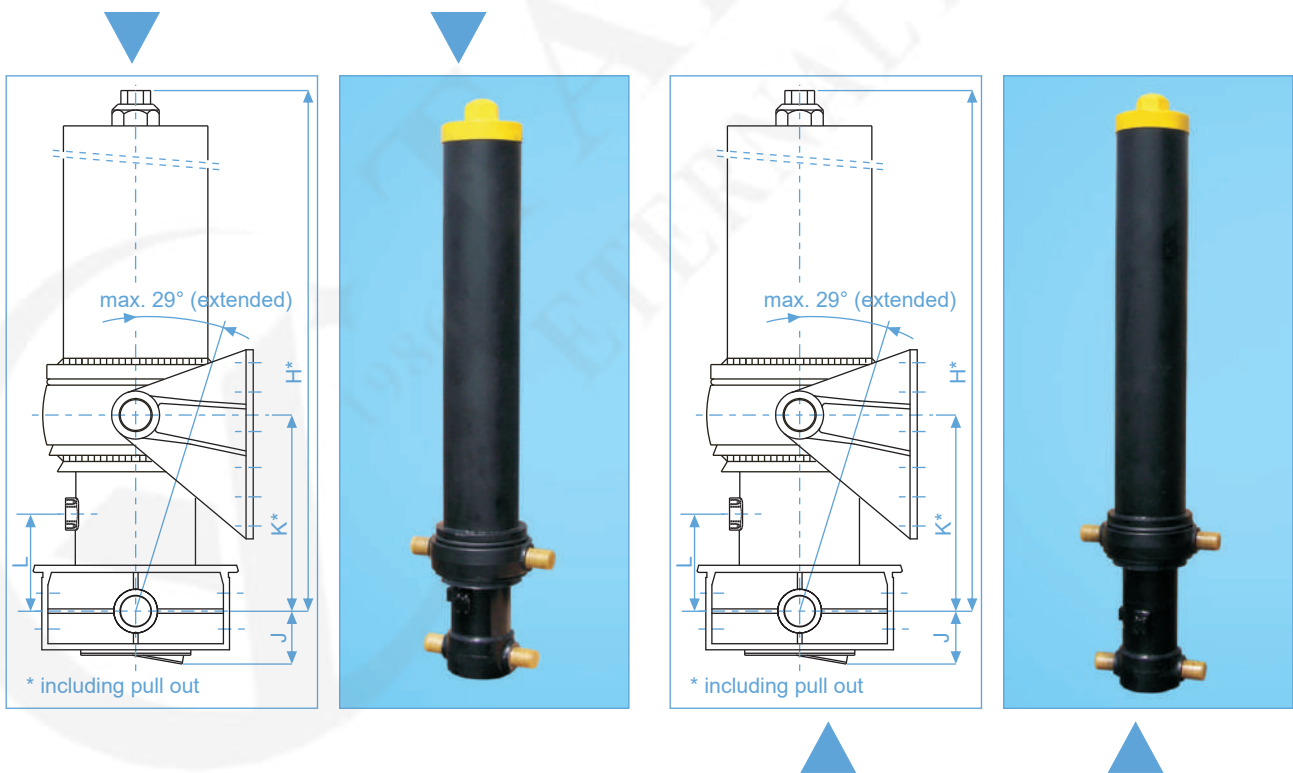

FC 214 Front-end cylinder with outer cover

Part no.	Kit no.	Description	Press (bar)	Tipping weight (tons)	Weight (kg.)	Vol. (ltr.)	Oil inlet	H* (mm)	J (mm)	K* (mm)	L (mm)
715 08 860	AL99860	FC 214-5-09030-000B-K0486	170	59 - 79	581	227	1"SAE	2197	135	486	190

* incl. 20 mm pull out (p.o.); tolerances -5 +30

FE 091, 110 & 129 front-end cylinders with eye

Part no.	Kit no.	Description	Press (bar)	Tipping weight (tons)	Weight (kg.)	Vol. (ltr.)	Oil inlet	H* (mm)	J (mm)	K* (mm)	L (mm)
715 32 160	AQ03160	FE 091-3-03205-001A-K1424	190	11 - 18	92	16	1"SAE	1477	81	1424	160
715 33 164	AQ13164	FE 110-3-03205-009A-K1399	190	21 - 46	98	24	1"SAE	1452	86	1399	190
715 33 200	AQ13200	FE 110-3-03700-001A-K1529	190	20 - 37	109	28	1"SAE	1582	86	1529	190
715 34 180	AQ23180	FE 129-3-03460-001A-K1449	190	33 - 59	129	37	1"SAE	1502	91	1449	190
715 34 220	AQ23220	FE 129-3-03880-001A-K1609	190	32 - 56	142	42	1"SAE	1652	91	1609	190

* incl. 20 mm pull out (p.o.); tolerances -5 +30

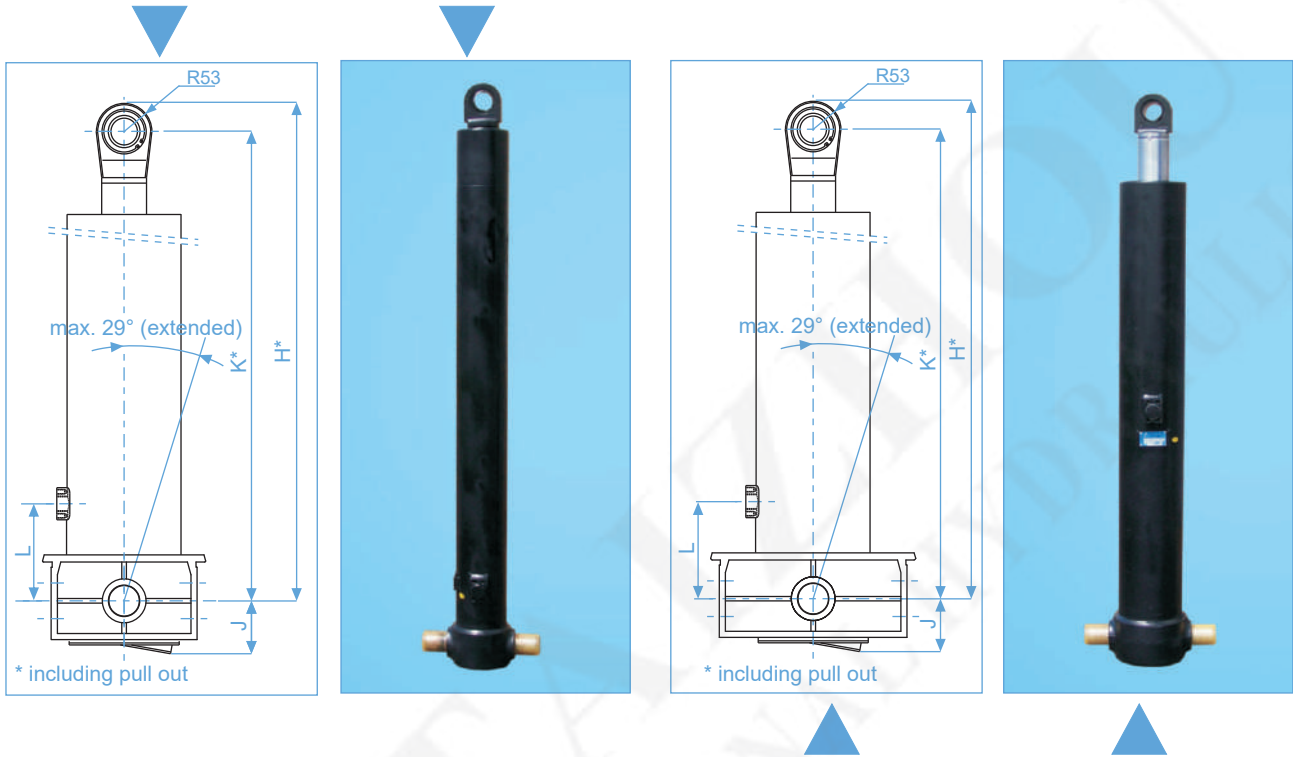

FE 149, 169, 191 & 214 front-end cylinders with eye

Part no.	Kit no.	Description	Press (bar)	Tipping weight (tons)	Weight (kg.)	Vol. (ltr.)	Oil inlet	H* (mm)	J (mm)	K* (mm)	L (mm)
715 35 226	AQ43226	FE 149-3-03880-009A-K1644	190	47 - 68	168	56	1"SAE	1697	96	1644	190
715 35 300	AQ44300	FE 149-4-04620-009A-K1484	190	35 - 70	171	59	1"SAE	1527	96	1484	190
715 35 320	AQ44320	FE 149-4-04940-001A-K1529	190	34 - 66	179	63	1"SAE	1582	96	1529	190
715 36 302	AQ64302	FE 169-4-04620-019A-K1479	190	51 - 83	206	78	1"SAE	1522	106	1479	700
715 36 392	AQ65392	FE 169-4-05180-011A-K1604	190	50 - 83	227	88	1"SAE	1657	106	1604	290
715 36 426	AQ75426	FE 169-5-05355-019A-K1394	190	35 - 66	212	80	1"SAE	1437	106	1394	700
715 36 470	AQ75470	FE 169-5-05780-019A-K1559	190	34 - 60	224	87	1"SAE	1612	106	1559	700
715 36 504	AQ76504	FE 169-5-06180-019A-K1559	190	34 - 58	236	93	1"SAE	1612	106	1559	700
715 36 522	AQ76522	FE 169-5-06480-011A-K1604	190	34 - 56	247	97	1"SAE	1657	106	1604	290
715 36 556	AQ76556	FE 169-5-06830-011B-K1674	170	30 - 48	258	102	1"SAE	1723	106	1674	700
715 36 594	AQ77594	FE 169-5-07130-019C-K1769	150	26 - 37	266	107	1"SAE	1822	106	1769	700
715 37 490	AQ86490	FE 191-5-06180-011A-K1527	190	49 - 84	281	122	1"SAE	1570	116	1527	700
715 37 668	AQ87668	FE 191-6-07420-019B-K1677	170	30 - 43	300	131	1"SAE	1720	116	1677	700
715 37 860	AQ89860	FE 191-5-09030-011E-K2177	110	27 - 36	395	177	1"SAE	2230	116	2177	290
715 38 584	AQ97582	FE 214-5-07130-011A-K1722	190	60 - 84	380	180	1"SAE	1784	135	1722	390

* incl. 20 mm pull out (p.o.); tolerances -5 +30

Dash pot and last stage double acting cylinders

Part no.	Kit no.	Description	Press (bar)	Tipping weight (tons)	Weight (kg.)	Vol. (ltr.)	Oil inlet	H* (mm)	J (mm)	K* (mm)	L (mm)
715 34 228	-	FE 129-3-03850-009A-K1609-DP	190	32 - 55	142	41	1"SAE	1662	91	1609	190
715 04 172	-	FC 129-3-03410-009A-K0343-1DA	190	34 - 57	172	37	1"SAE	1484	91	343	190
715 05 380	-	FC 149-4-05150-009A-K0343-1DA	190	34 - 67	260	66	1"SAE	1644	96	343	190

* incl. 20 mm pull out (p.o.); tolerances -5 +30

Three-way under body tipping cylinder UMB/UME

UMB/UME cylinders are delivered including a BSPOT adapter. The tipping weight is calculated at 220 bar (is maximum working pressure). The cradle, knock-off and brackets need to be ordered separately.

Part no.	Description	Tipping weight (tons)	Body length	Weight (kg.)	Oil inlet	ØW (mm)	K* (mm)
714 04 203	UMB 129-3-0700-K318-45-1/2"-HC	15 - 21	2400 - 3100	46	1/2"	45	318
714 04 291	UMB 129-4-1020-K205-45-1/2"-HC	12 - 20	3100 - 4000	49	1/2"	45	205
714 04 429	UMB 129-4-1500-K205-45-1/2"-HC	11 - 20	4100 - 5400	60	1/2"	45	205
714 04 421	UMB 129-5-1480-K192-45-1/2"-HC	6 - 17	4100 - 5400	59	1/2"	45	192
714 04 537	UMB 129-5-1880-K192-45-1/2"-HC	6 - 17	4900 - 6500	67	1/2"	45	192
714 05 429	UMB 149-4-1500-K265-50-3/4"-HC	18 - 28	4300 - 5600	76	3/4"	50	265
714 05 365	UMB 149-5-1280-K258-50-3/4"-HC	12 - 23	3800 - 5000	64	3/4"	50	258
714 05 421	UMB 149-5-1480-K258-50-3/4"-HC	12 - 23	4200 - 5600	69	3/4"	50	258
714 05 537	UMB 149-5-1880-K258-50-3/4"-HC	11 - 23	5100 - 6700	79	3/4"	50	258
714 05 509	UMB 149-6-1780-K245-50-3/4"-HC	6 - 17	4900 - 6400	75	3/4"	50	245
714 06 421	UMB 169-5-1480-K265-50-3/4"-HC	19 - 29	4400 - 5800	84	3/4"	50	265
714 06 537	UMB 169-5-1880-K265-50-3/4"-HC	18 - 28	5300 - 7000	96	3/4"	50	265
714 06 509	UMB 169-6-1780-K258-50-3/4"-HC	12 - 23	5000 - 6700	86	3/4"	50	258
714 06 647	UMB 169-6-2260-K258-50-3/4"-HC	13 - 25	5600 - 7300	99	3/4"	50	258
714 06 517	UMB 169-7-1800-K245-50-3/4"-HC	7 - 17	5100 - 6700	85	3/4"	50	245
714 06 675	UMB 169-7-2360-K245-50-3/4"-HC	7 - 19	5700 - 7500	99	3/4"	50	245
714 07 511	UMB 191-6-1780-K270-60-3/4"-HC	19 - 34	5000 - 6700	107	3/4"	60	270
714 07 519	UMB 191-7-1800-K278-60-3/4"-HC	12 - 28	5100 - 6800	108	3/4"	60	278
714 07 681	UMB 191-8-2380-K278-60-3/4"-HC	7 - 22	5800 - 7600	116	3/4"	60	278

* K dimension is including 20 mm pull-out -0 +20

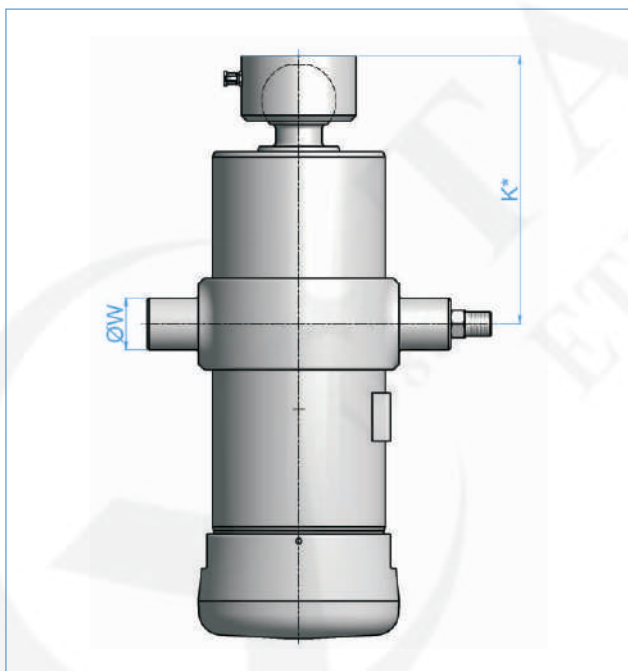

Seal kits for UMB/UME cylinders

Part no.	Description
719 04 430K	Seal kit complete UM 129 - 3
719 04 440K	Seal kit complete UM 129 - 4
719 04 450K	Seal kit complete UM 129 - 5
719 04 451K	Seal kit complete UM 129 - 5 (>500)*
719 04 540K	Seal kit complete UM 149 - 4
719 04 550K	Seal kit complete UM 149 - 5
719 04 560K	Seal kit complete UM 149 - 6
719 04 650K	Seal kit complete UM 169 - 5
719 04 660K	Seal kit complete UM 169 - 6
719 04 670K	Seal kit complete UM 169 - 7
719 04 ???K	Seal kit complete UM 191 - 6
719 04 ???K	Seal kit complete UM 191 - 7
719 04 ???K	Seal kit complete UM 191 - 8

* Kits marked with (>L) to be used for cylinders with the tube lengths exceeding the listed length.



Nipple for oil inlet UMB/UME

Part no.	Description
731 03 000	Oil inlet nipple UM 1/2" - M18 x 1,5
731 03 002	Oil inlet nipple UM 3/4" - M22 x 1,5



Brackets for UMB/UME cylinders

(2 required)

Part no.	Description	ØR (mm)	S (mm)	T (mm)	U (mm)	V (mm)	W (mm)	ØX (mm)	Weight (kg)
731 05 073	Bracket UM 129 to bolt D45	45,5	105	140	45	33	15	15	1,0
731 05 076	Bracket UM 149-169 to bolt D50	50,5	120	155	50	37	17	15	1,4
731 05 079	Bracket UM 191 to bolt D60	60,5	130	165	50	42	17	15	1,6

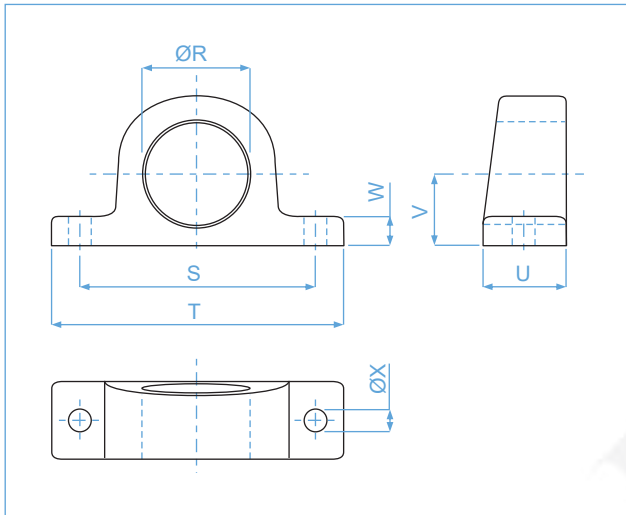

Weldable brackets for cradles

(2 required)

Part no.	Description	For Cradle	ØR (mm)	S (mm)	T (mm)	U (mm)	V (mm)	W (mm)	ØX	Weight (kg)
731 05 035	Welding bracket UM D50	129-169	50	80	122	39	20	85	M12	1,5
731 05 036	Welding bracket UM D60	191	60	90	122	39	25	90	M12	2,1

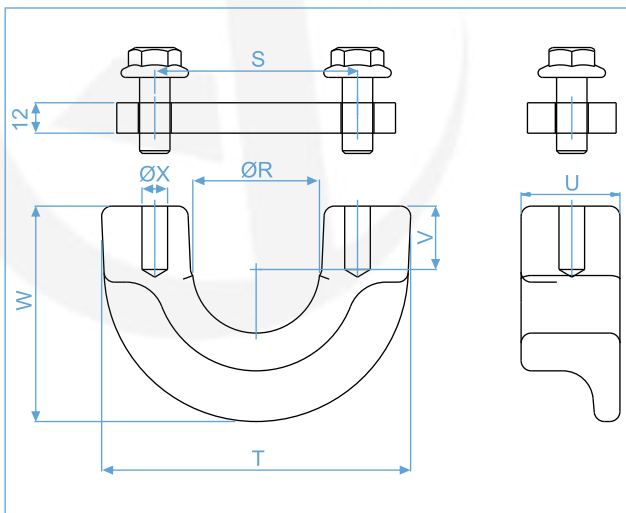

Cradles for UMB/UME cylinders

Part no.	Description	J (mm)	K (mm)	L (mm)	ØM (mm)	N (mm)	O (mm)	ØP (mm)	Q (°)	Weight (kg)
731 04 021	Cradle UM 129 - PIN50-D45	280	180	135	45	35	39	50	60	13,8
731 04 031	Cradle UM 149 - PIN50-D50	330	210	152	50	37	39	50	60	20,4
731 04 041	Cradle UM 169 - PIN50-D50	380	235	162	50	37	39	50	60	26,5
731 04 051	Cradle UM 191 - PIN60-D60	400	250	190	60	45	39	60	60	38,9

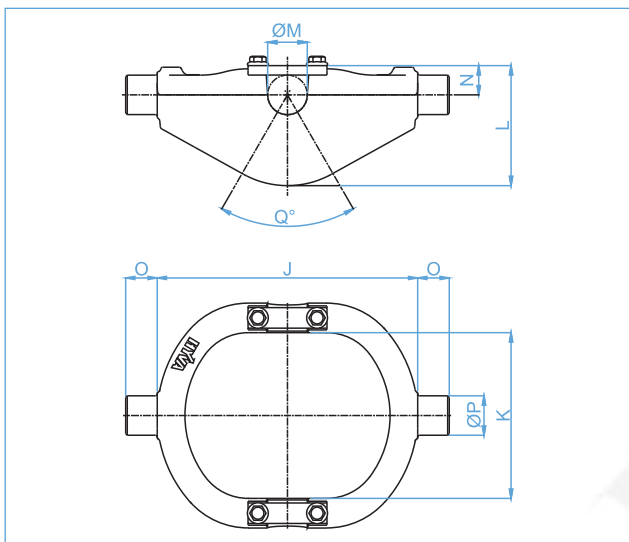

Cradles with knock-off and brackets for UMB/UME cylinders

Part no.	Description	G (mm)	H (mm)	J (mm)	K (mm)	L (mm)	ØM (mm)	N (mm)	O (mm)	ØP (mm)	Q (°)	T (mm)	Weight (kg)
731 04 033	Cradle UM 149 - KOPN-PIN50-D50	310	137	330	210	152	50	37	39	50	60	122	26,7
731 04 043	Cradle UM 169 - KOPN-PIN50-D50	320	137	380	235	162	50	37	39	50	60	122	33,0
731 04 053	Cradle UM 191 - KOPN-PIN60-D60	340	147	400	250	190	60	45	39	60	60	122	45,6

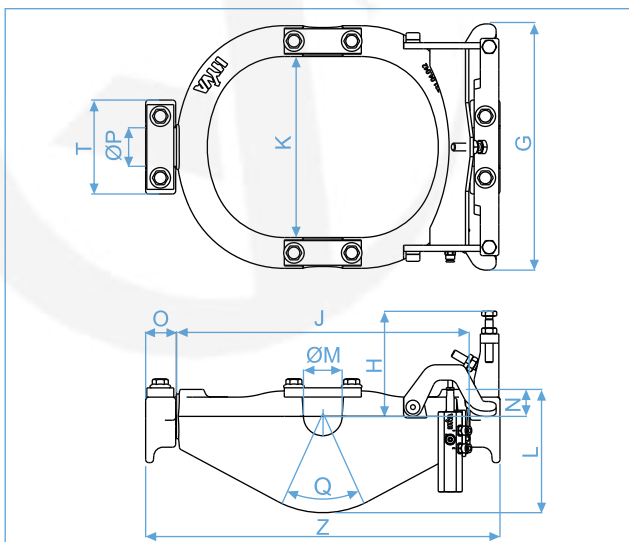

Three-way underbody tipping cylinder KR

KRA/KRM cylinders are delivered including a 3/4" BSPOT adapter. The working pressure of the cylinders is 280 Bar (300 max.) The cradle, knock-off and brackets are already mounted. KRM standard has a pneumatic knock-off, KRA standard has a hydraulic knock-off. The tipping weight is calculated at 275 bar.

KRM cylinders

Part no.	Description	Tipping weight (tons)	Kg.	Ltr.	I (mm)	K* (mm)	C (mm)	A (mm)	cradle /ball
014 12 060	KRM 145/6/1465	9 - 20	89	12,1	130	316	170	180	2/3
014 12 080	KRM 145/6/1825	9 - 20	99	14,9	130	376	170	180	2/3
014 12 110	KRM 167/5/1410	22 - 32	132	18,9	145	353	196	207	3/4
014 12 210	KRM 167/6/1680	15 - 26	131	19,8	146	331	196	207	3/3
014 12 215	KRM 167/6/1860	15 - 26	139	21,9	146	361	196	207	3/3
014 12 220	KRM 167/6/2040	14 - 25	147	24,0	146	391	196	207	3/3
014 12 240	KRM 167/7/2155	11 - 22	137	23,0	146	369	196	207	3/3
014 12 255	KRM 193/6/1695	20 - 32	206	27,2	190	312	228	240	4/4
014 12 280	KRM 193/7/1955	16 - 28	207	28,4	190	312	228	240	4/4
014 12 285	KRM 193/7/2165	18 - 32	217	31,4	190	342	228	240	4/4
014 12 308	KRM 193/8/2705	14 - 25	150	35,3	190	364	228	240	4/3
014 12 590	KRM 223/7/2375	20 - 38	250	51,3	200	362	260	260	4/4
014 12 610	KRM 223/8/2215	18 - 38	230	38,7	200	316	260	260	4/4
014 12 615	KRM 223/8/2455	18 - 38	240	42,8	200	346	260	260	4/4
014 12 680	KRM 223/9/2775	11 - 28	250	49,0	200	346	260	260	4/4

* incl. 15 mm pull out (p.o.); tolerances -0 +15



KRA cylinders

Part no.	Description	Tipping weight (tons)	Kg.	Ltr.	I (mm)	K* (mm)	C (mm)	A (mm)	cradle /ball
014 11 200 A	KRA 125/3/1635	15 - 20	125	15,2	435	365	148	180	2/3
014 12 045 A	KRA 145/3/1485	18 - 23	164	18,7	290	435	170	205	3/5
014 11 480 A	KRA 167/3/2535	28 - 35	266	43,2	610	515	196	228	3/5
014 12 008 A	KRA 167/6/2385	13 - 29	154	28,1	305	315	196	228	3/3
014 12 009 A	KRA 193/5/2235	28 - 35	258	39,8	316	385	228	266	4/5
014 12 038 A	KRA 193/5/3835	28 - 35	368	68,2	541	515	228	266	4/5

* incl. 15 mm pull out (p.o.); tolerances -0 +15

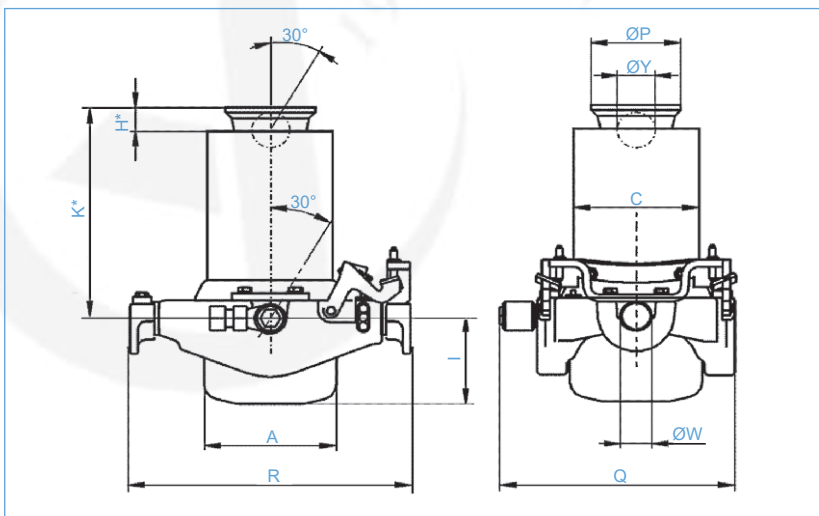

Cradle dimensions

Cradle	Type 2	Type 3	Type 4
R(mm)	369	472	538
Q(mm)	359	370	455
W(mm)	50	50	60

Ball & cup dimensions

Ball & cup	Type 3	Type 4	Type 5
P(mm)	125	145	145
Y(mm)	60	75	80