

一、P 系列多路阀 P Series Directional Control Valve

P40 系列 P40 Series	1
Z50 电磁控系列 Z50 Solenoid Control Valve	3
P40 系列电液控多路阀 P40 Electric and Hydraulic Control Valve	5
P80 系列 P80 Series	7
P80 电磁控系列 P80 Solenoid Control Valve	9
P80 系列电液控多路阀 P80 Electric and Hydraulic Control Valve	11

二、ZD(ZT)系列多路阀 ZD(ZT) Series Directional Control Valve

ZD-L102 系列 ZD-L102 Series.....	19
BDL-L40 系列 BDL-L40 Series.....	21
ZD-L15 系列 ZD-L15 Series.....	23
ZD-L15 气控系列 ZD-L15 Pneumatic Control Valve.....	25
ZD-L15 电气控系列 ZD-L15 Electric and Pneumatic Control Valve.....	27
ZDa-L15 系列 ZDa-L15 Series.....	29
ZDa-L15 气控系列 ZDa-L15 Pneumatic Control Valve.....	31
ZDa-L15 电气控系列 ZDa-L15 Electric and Pneumatic Control Valve.....	33
ZDa-L15 电液控系列 ZDa-L15 Electric and Hydraulic Control Valve.....	35
ZT-L20 系列 ZT-L20 Series.....	37
ZT-L20 气控系列 ZT-L20 Pneumatic Control Valve.....	39
ZT-L20 电气控系列 ZT-L20 Electric and Pneumatic Control Valve.....	41

三、SD 系列多路阀 SD Series Directional Control Valve

SD 系列整体阀 SD Series mono block control valves	43
SD4 系列 SD4 Series	43
SD5 系列 SD5 Series	45
SD5 电磁控系列 SD5 Solenoid Control Valve	47
SD11 系列 SD11 Series	49
SD14 系列 SD14 Series	51
SMD141 滑移式装载机专用阀系列 SDM141 Series.....	53
SD18 系列 SD18 Series	55

SD 系列分片阀 SD Series sectional control valves	57
SD8 系列 SD8 Series	57
SD8 系列液控多路阀 SD8 Hydraulic Pilot Control Valve.....	59
SDS180 系列 SDS180 Series.....	61
SDS180 系列液控多路阀 SDS180 Hydraulic Pilot Control Valve	63
SD25 系列 SD25 Series	65
SD25 系列液控多路阀 SD25 Hydraulic Pilot Control Valve	67
SDS400 系列 SDS400 Series.....	69
SDS400 系列液控多路阀 SDS400 Hydraulic Pilot Control Valve	71

四、DCV 系列多路阀 DCV Series Directional Control Valve

DCV 系列整体阀 DCV Series mono block control valves	73
DCV20 系列 DCV20 Series	73
DCV40 系列 DCV40 Series	75
DCV40 气控系列 DCV40 Pneumatic Control Valve	77
DCV40 电气控系列 DCV40 Electric and Pneumatic Control Valve.....	79
DCV40 电液控系列 DCV40 Electric and Hydraulic Control Valve.....	81
DCV 系列分片阀 SD Series sectional control valves	83
DCV 系列分体式多路阀如何订货及相关说明.....	83
How to order DCV series sectional control valves	83
DCV60 系列 DCV60 Series	95
DCV100 系列 DCV100 Series	102
DCV140 系列 DCV140 Series	108

五、其他多路阀 Other Directional Control Valves

ZS 系列 ZS Series	112
ZS1 系列 ZS1 Series	113
ZS1-L10 系列 ZS-L10 Series.....	114
ZS1-L15 系列 ZS1-L15 Series.....	115
ZS3 系列 ZS3 Series	117
ZS3-L10 系列 ZS-L10 Series.....	118
ZS3-L20 系列 ZS-L20 Series.....	119

MB 系列 MB Series	120
RD5000 系列 RD5000 Series	125
DL 系列 DL Series	128
DL-L15 系列 DL-L15 Series.....	132
SQDL-L15 系列 SQDL-L15 Series	134
YDL-L15 系列 YDL-L15 Series	136
DL-L20 系列 DL-L20 Series.....	138
SQDL-L20 系列 SQDL-L20 Series	140
YDL-L20 系列 YDL-L20 Series	142
DL-8 系列 DL-8 Series	144
DF-50 系列 DF50 Series	147
CDB 系列 CDB Series	150
CDB-F15 系列 CDB-F15 Series	153
ZCDB-F15 系列 ZCDB-F15 Series	154
CDB-F20 系列 CDB-F20 Series	156
ZCDB-F20 系列 ZCDB-F20 Series	157
ZY08 系列 ZY08 Series	158

六、其他液压阀和配件 Other hydraulic control valves and Parts

LKF 系列流量控制阀 LKF Series Flow Control Valve	160
SVV06 电磁切换阀 SVV06 Solenoid Diverter Valve	162
DVS90 电磁切换阀 DVS90 Solenoid Diverter Valve	164
SVV09 电磁切换阀 SVV09 Solenoid Diverter Valve	166
转阀 Rotary Spool Valve	168
LVA 劈木机阀系列 LVA Series Log Splitter Valve	171
BZZ 型全液压转向器 BZZ Hydraulic Steering Units	173

Mode Code

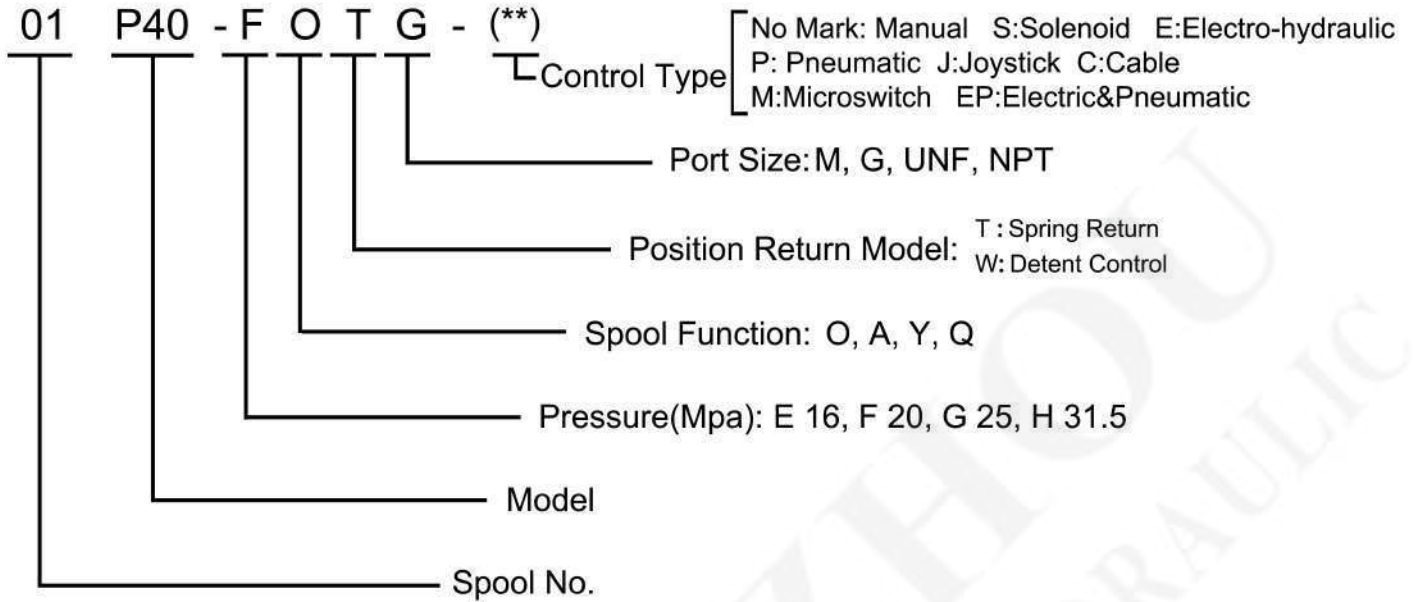

Spool Function Symbols



O Spool Function



Y Spool Function

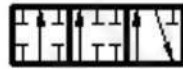

A Spool Function

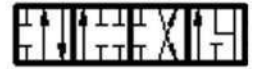

Q Spool Function

Port Size

Flow	M	G	UNF	NPT
≤60L	M18x1.5	G 3/8"	3/4-16 UNF	NPT 3/8"
60-80L	M22x1.5	G 1/2"	7/8-14 UNF	NPT 1/2"
100-140L	M27x2	G 3/4"	1- 1/16-12 UNF	NPT 3/4"
140-160L	M33x2	G 1"	1- 5/16-12 UNF	NPT 1"
160-240L	M42x2	G 1-1/2"	1- 5/8-12 UNF	NPT 1-1/2"

If you need special dimension port size, please consult to our Engineer.

ZD-L102系列整体阀

ZD-L102 Series Monoblock Directional Control Valves.

用途与特征/APPLICATIONS&FEATURES

ZD-L102多路换向阀是我单位自主设计开发的一种中高压整体式多路换向阀。可按客户要求可在阀上设溢流阀、单向阀等。溢流阀可调节系统压力，单向阀防止油液倒流，换向阀滑阀机能A、O、Y、P等，可任意组合，换向手柄有两种安装形式，便于不同方向的操作，并采用并联油路。经过特殊设计的密封方式，使阀的密封性能卓越。该阀广泛用于叉车、环卫车辆、小型装载机等工程机械的液压系统。



Model ZD-L102 with middle-high pressure monoblock construction is an independently developed control valves by our company.

- ◆ Inner check valve: The check valve inside the valve body is to insure the hydraulic oil not to be returned.
- ◆ Inner relief valve: The relief valve inside the valve body is able to adjust the hydraulic system working pressure.
- ◆ Oil way: Parallel circuit
- ◆ Control Way: Manual control
- ◆ Valve construction: monoblock construction, 1-3 levers.
- ◆ Spool Function: O, Y, P, A.

性能参数/SPECIFICATIONS

公称压力 Nominal Pressure (Mpa)	最大压力 Max. pressure (Mpa)	公称流量 Nom. flow (L/min)	允许背压 Allowable Back pressure (Mpa)	工作油液 Hydraulic Oil		
				温度范围 Tem.range (℃)	粘度范围 Visc.range (mm ² /s)	过滤精度 Filtrating accuracy (μm)
16	20	40	≤1	-20~+80	10~400	≤10

注：油液最高污染等级：按GB/T14039之19/16
Note: maximum permissible degree of contamination of the oil is according to GB/T14039-19/16

型号说明/MODEL CODE

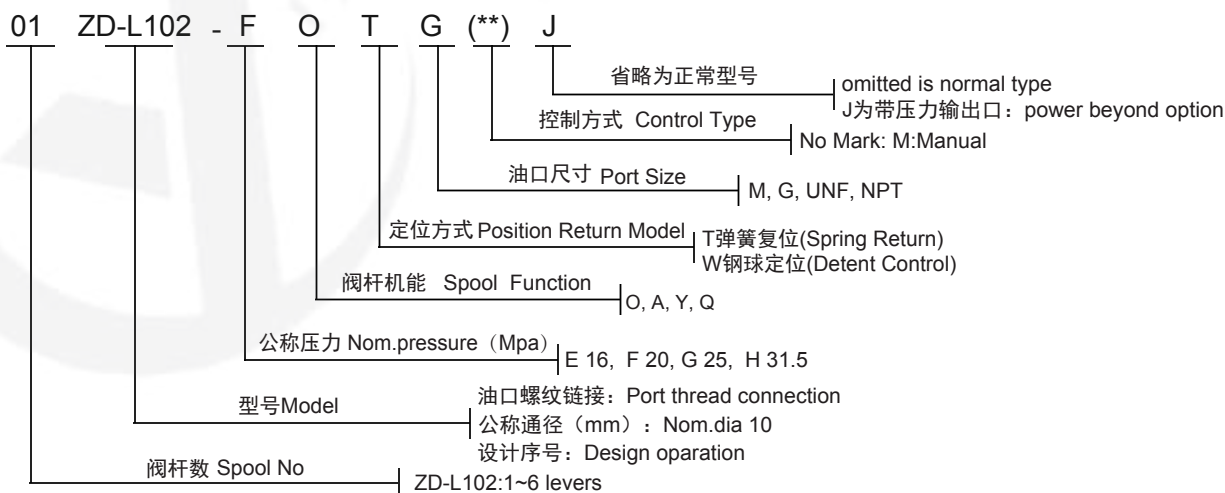

注：订货有特殊要求者，请与销售顾问联系。
Note: Special features not listed on can often be made to your specifications. Please consult your sales representative.

BDL-L40系列整体阀

BDL-L40 Series Monoblock Directional Control Valves.

用途与特征/APPLICATIONS&FEATURES

BDL-L40多路换向阀是我单位主要设计开发的一种中高压整体式换向阀，可按客户要求可在阀上设溢流阀。溢流阀可调节系统压力，换向阀机能可有M.O.Y.P。该阀广泛用于子叉车、环卫车辆、小型装载机等工程机械的液压系统。

Model BDL-L40 with middle-high pressure monoblock and single spool construction is an independently developed control valves by our company.

- ◆ Inner relief valve: The relief valve inside the valve body is able to adjust the hydraulic system working pressure.
- ◆ Oil way: Parallel circuit,
- ◆ Control Way: Manual control
- ◆ Valve construction: monoblock construction, single levers.
- ◆ Spool Function: M,O,Y, P.



性能参数/SPECIFICATIONS

公称压力 Nominal Pressure (Mpa)	最大压力 Max. pressure (Mpa)	公称流量 Nom. flow (L/min)	允许背压 Allowable Back. pressure (Mpa)	工作油液Hydraulic Oil		
				温度范围 Tem.range (°C)	粘度范围 Visc.range (mm2/s)	过滤精度 Filtrating accuracy (μm)
16	25	40	≤1	-20~+80	10~400	≤10

注：油液最高污染等级:按GB/T14039之19/16

Note:maximum permissible degree of contamination of the oil is according to GB/T14039-19/16

型号说明/MODEL CODE

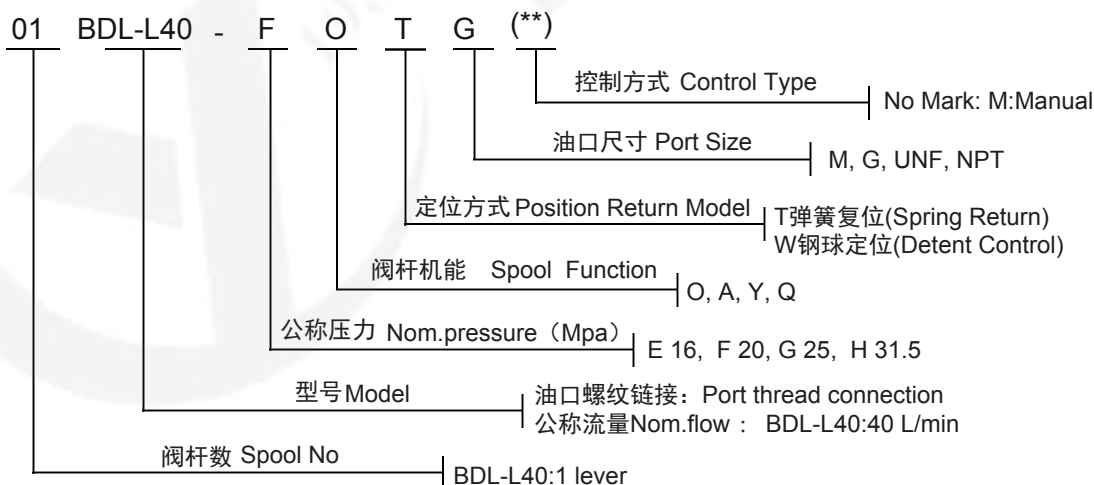

注：订货有特殊要求者，请与您的销售代表联系。

Notes:Special features not listed can often be made to your specifications, Please consult your sales representative.

BDL-L40系列整体阀

BDL-L40 Series Monoblock Directional Control Valves.

BDL-L40外形安装连接尺寸/Model BDL-L40 DIMENSIONAL DATA

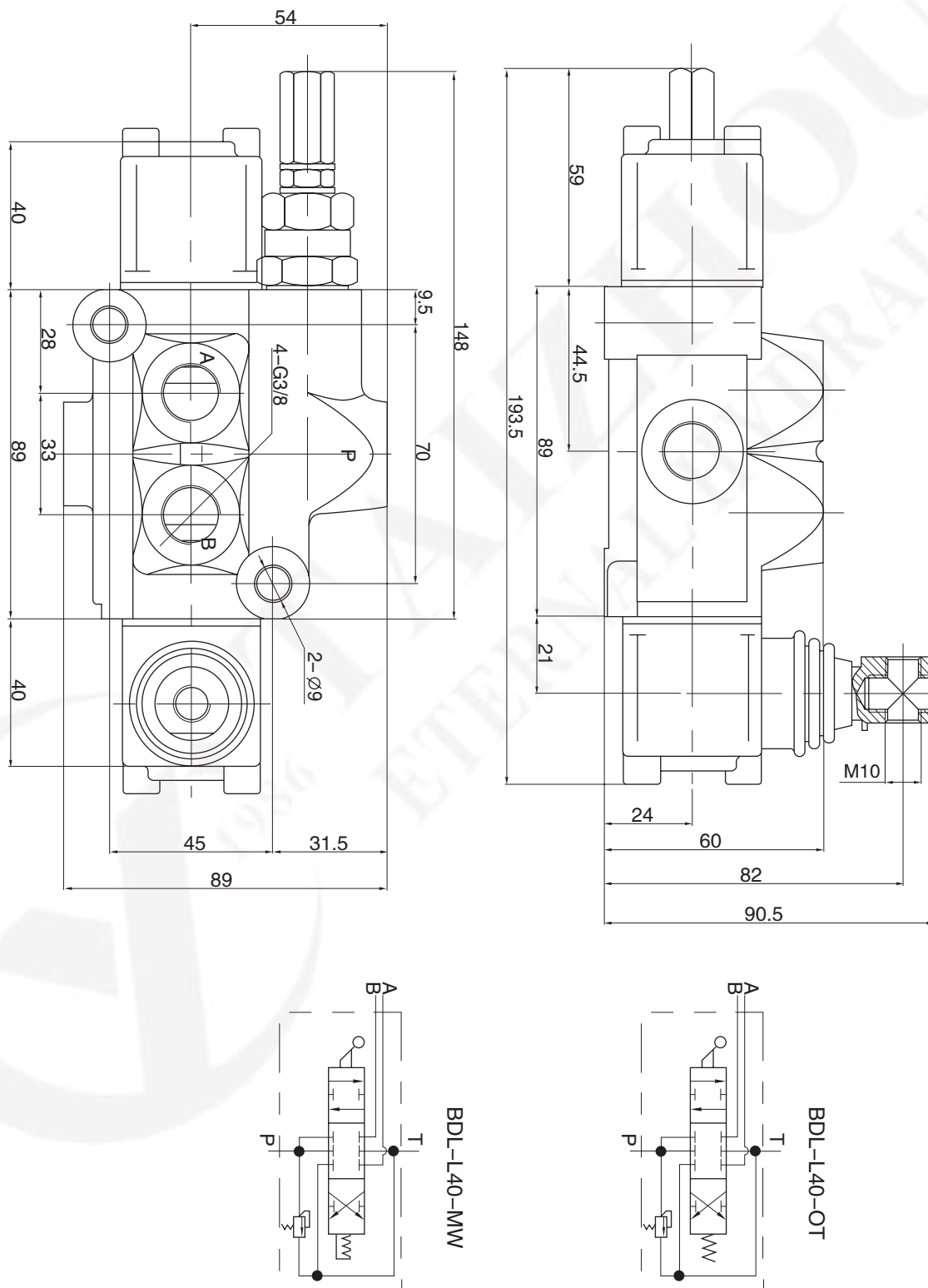

ZD-L15系列整体阀

ZD-L15 Series Monoblock Directional Control Valves.

用途与特征/APPLICATIONS&FEATURES

ZD-L15多路换向阀是我单位自主设计开发的一种中高压整体式多路换向阀。可按客户要求可在阀上设溢流阀、单向阀、补油阀等。溢流阀可调节系统压力，单向阀防止油液倒流，换向阀阀机能能有A、O、Y、P等，可任意组合。换向手柄有两种安装形式，便于不同方向的操作。该阀采用并联油路，设计有压力出口与其它液压元件相接提供动力源。经过特殊设计的密封方式，使阀的密封性能卓越。该阀广泛用于叉车、环卫车辆、小型装载机等工程机械的液压系统。



Model ZD-L15 with middle-high pressure monoblock construction is an independently developed control valves by our company.

◆ Inner check valve: The check valve inside the valve body is to insure the hydraulic oil not to be returned.

◆ Inner relief valve: The relief valve inside the valve body is able to adjust the hydraulic system working pressure.

◆ Oil way: Parallel circuit, power beyond option

◆ Control Way: Manual control, pneumatic control, hydraulic and electric control for optional.

◆ Valve construction: monoblock construction, 2-4 levers.

◆ Spool Function: O, Y, P, A.

性能参数/SPECIFICATIONS

公称压力 Nominal Pressure (Mpa)	最大压力 Max. pressure (Mpa)	公称流量 Nom. flow (L/min)	允许背压 Allowable Back. pressure (Mpa)	工作油液 Hydraulic Oil		
				温度范围 Tem.range (°C)	粘度范围 Visc.range (mm ² /s)	过滤精度 Filtrating accuracy (μm)
16	31.5	63	≤ 1	-20~+80	10~400	≤ 10

注：油液最高污染等级：按GB/T14039之19/16

Note: maximum permissible degree of contamination of the oil is according to GB/T14039-19/16

型号说明/MODEL CODE

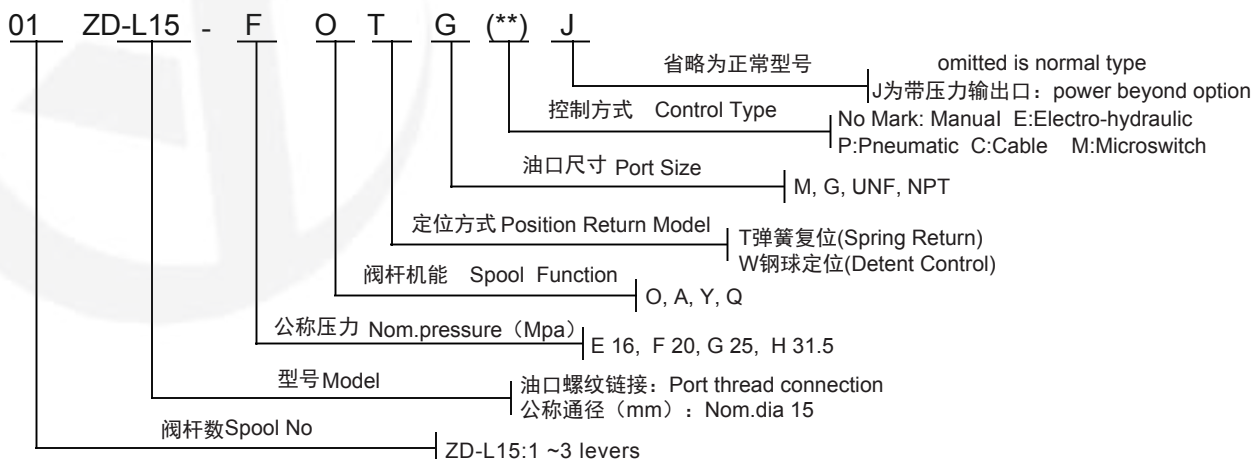

注：订货有特殊要求者，请与您的销售代表联系。

Notes: Special features not listed can often be made to your specifications, Please consult your sales representative.

ZD-L15系列整体阀

ZD-L15 Series Monoblock Directional Control Valves.

ZD-L15外形安装连接尺寸/MODEL ZD-L15 DIMENSIONAL DATA

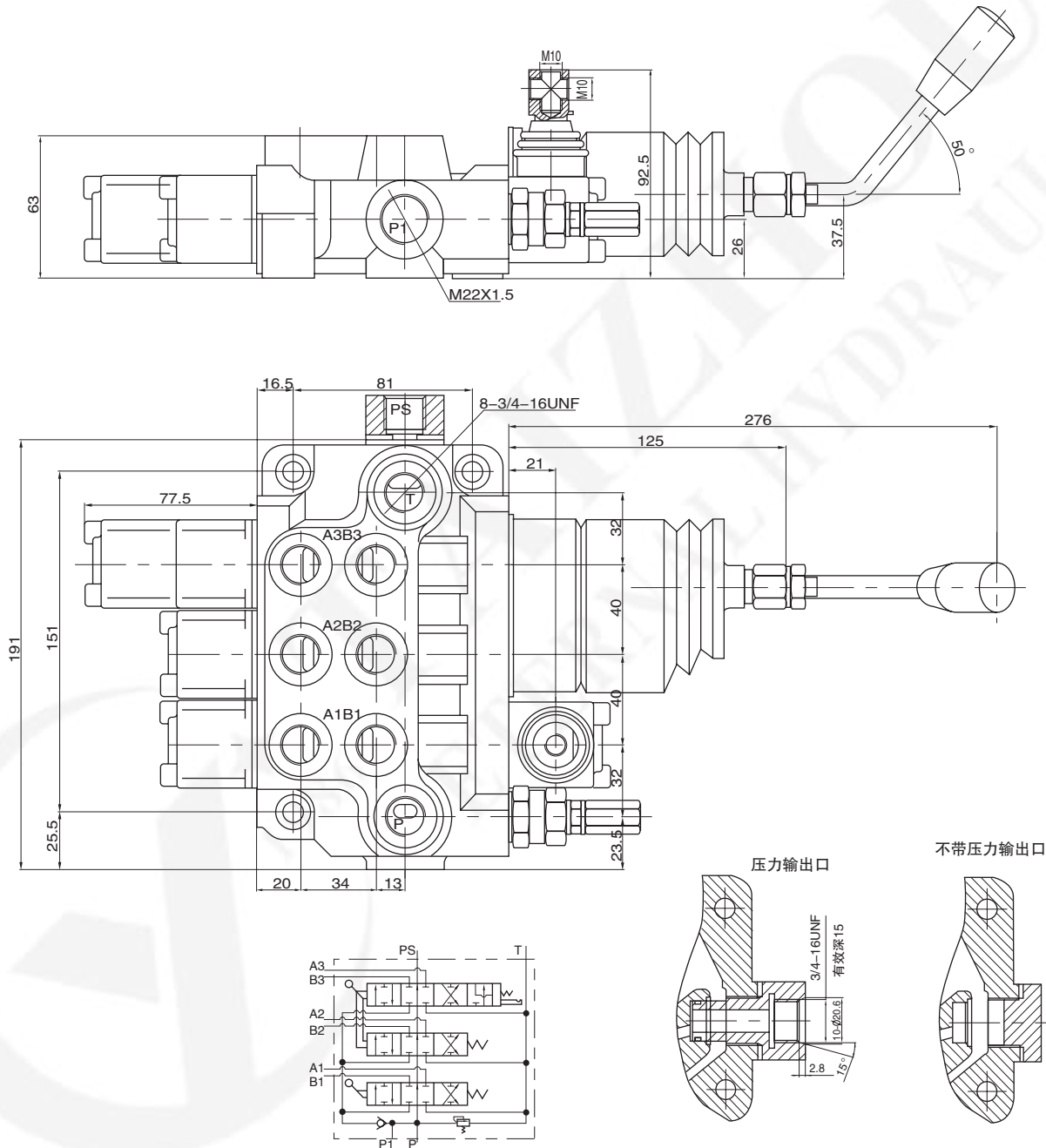

ZD-L15气控系列多路阀

ZD-L15 Pneumatic Control Valve

产品特点 /APPLICATIONS&FEATURES

ZD-L15气控系列多路阀是在ZD-L15手动控制系列的基础上改进而来。它主要是改变了手动换向阀的操纵机构，在手动的基础上增加了气动控制，能够更好地实现远程控制。ZD-L15系列多路阀的回油端设置了压力输出口，可与其他液压元件串联使用。该阀为整体式，具有结构紧凑，工作压力高，性能好，工作可靠，可实现多个执行机构的近、远程控制的优点。根据用户需要，换向阀的操纵机构可以和普通手动控制进行任意组合。该阀广泛应用于工程机械、环卫机械、矿山机械和其他机械的液压系统。

ZD-L15 series pneumatic control valves are developed on ZD-L15 manual control valves. It changed the control way of these valves, especially, it can be controlled by remote control with the pneumatic control way. The power beyond function is on the ZD-L15 series, it is able to be connected with other hydraulic valves in series. The features of the monoblock construction ZD-L15 pneumatic control valves are compact construction, high working pressure, better functions, reliable working, remote controlling and etc. Besides that, the manual control can be used with the pneumatic control together. The valves are widely used on mechanical machines, sanitation machines, mining machines and other machines' hydraulic systems.

- ◆ 内置单向阀：阀体内置单向阀，防止油液倒流
- ◆ Inner check valve: The check valve inside the valve body is to insure the hydraulic oil not be returned.
- ◆ 内置安全阀：阀体内置溢流阀，可调节控制系统压力
- Inner relief valve: The relief valve inside the valve body is able to adjust the hydraulic system working pressure.
- ◆ 油路形式：并联油路，带压力输出口
- Oil way: Parallel circuit, with power beyond.
- ◆ 控制方式：气控换向，也可手动换向
- Control Way: pneumatic control, manual control
- ◆ 阀体结构：整体结构，2-4联任意组合
- Valve construction: monoblock construction, 2-4 levers are available to assembled as you requests.
- ◆ 阀杆机能：O、A、Y等
- Spool Function: O,A,Y etc.

型号说明/MODEL CODE

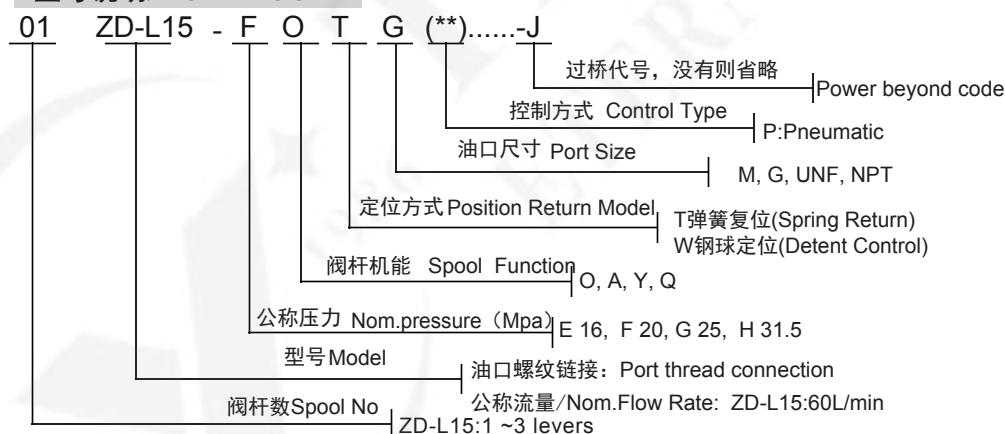

技术参数/PARAMETERS

公称压力 (MPa) Nom. Pressure	最大压力 (MPa) Max. Pressure	公称流量 (L/min) Nom. Flow rate	最大流量 (L/min) Max. Flow rate	中位背压 (MPa) Back Pressure	工作油液hydraulic oil		
					温度范围 (℃) Tem.rang	粘度范围 (mm2/S) Visc.rang	过滤精度 (μm) filtrating accuracy
20	31.5	50	60	≤1	-20 ~ +80	10 ~ 400	≤10

注：订货有特殊要求者，请与您的销售代表联系。

Notes:Special features not listed can often be made to your specifications, Please consult your sales representative.

ZD-L15气控系列多路阀

ZD-L15 Pneumatic Control Valve

ZD-L15外形安装连接尺寸/MODEL ZD-L15 DIMENSIONAL DATA

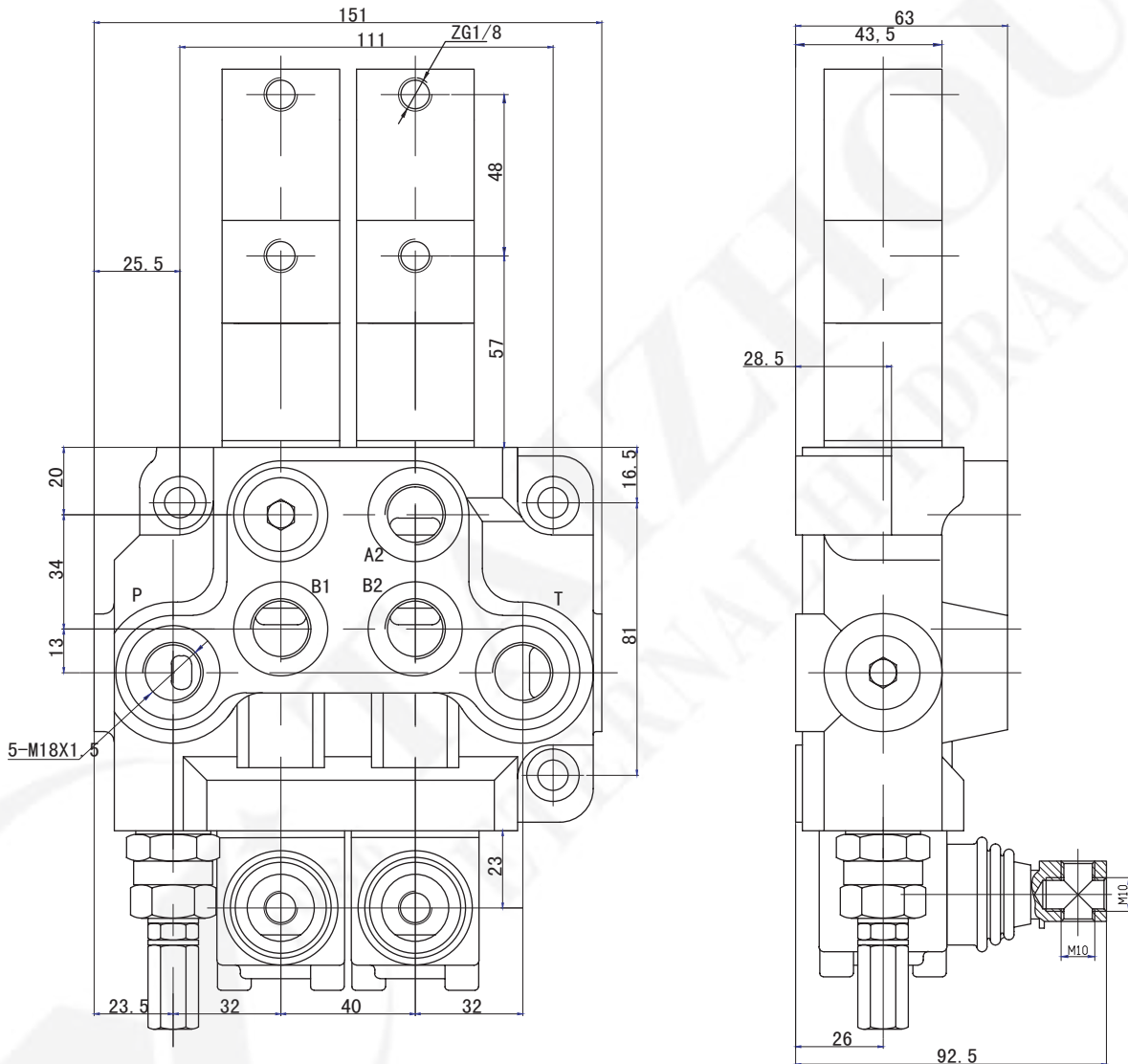

原
理
图

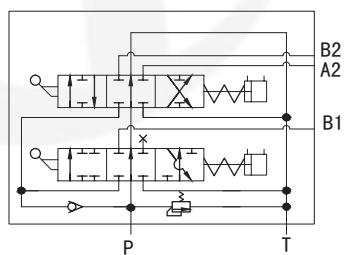

技术参数:

1. 公称通径: 15mm
2. 公称压力: 16MPa,
3. 最大流量: 60L/min.

ZD-L15电气控系列整体阀

ZD-L15 Electric and Pneumatic Control Valve

用途与特征/APPLICATIONS&FEATURES

ZD-L15电气控制系列多路阀是在ZD-L15气控系列的基础上改进而来。它主要是改变了气控换向阀的操纵机构，在气控的基础上增加了电气控制，并且可以根据客户需求，安装无线遥控，能够更好地实现远程控制。该阀广泛应用于工程机械、环卫机械、矿山机械和其他机械的液压系统。

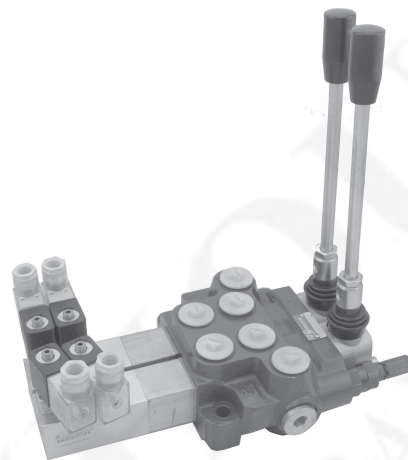

产品特点/FEATURES

- ◆ 内置单向阀：阀体内置单向阀，防止油液倒流
- ◆ 内置安全阀：阀体内置溢流阀，可调节控制系统压力
- ◆ 油路形式：并联油路，带压力输出口
- ◆ 控制方式：气控换向，也可手动换向
- ◆ 阀体结构：整体结构，2-4联任意组合
- ◆ 阀杆机能：O、A、Y等
- ◆ Inner check valve: The check valve inside the valve body to insure the hydraulic oil not to be returned.
- ◆ Inner relief valve: The relief valve inside the valve body is able to adjust the hydraulic system working pressure.
- ◆ Oil way: Parallel circuit, with power beyond.
- ◆ Control Way: pneumatic control, manual control
- ◆ Valve construction: monoblock construction, 2-4 levers are available to be assembled as you requests.
- ◆ Spool Function: O,A,Y etc.

性能参数/SPECIFICATIONS

公称压力 (MPa) Nom. Pressure	最大压力 (MPa) Max. Pressure	公称流量 (L/min) Nom. Flow rate	最大流量 (L/min) Max. Flow rate	中位背压 (MPa) Back Pressure	工作油液hydraulic oil		
					温度范围 (℃) Tem.rang	粘度范围 (mm ² /S) Visc.rang	过滤精度 (μm) filtrating accuracy
20	31.5	50	60	≤1	-20 ~ +80	10 ~ 400	≤10

注：油液最高污染等级：按GB/T14039之19/16
Note: maximum permissible degree of contamination of the oil is according to GB/T14039-19/16

型号说明/MODEL CODE

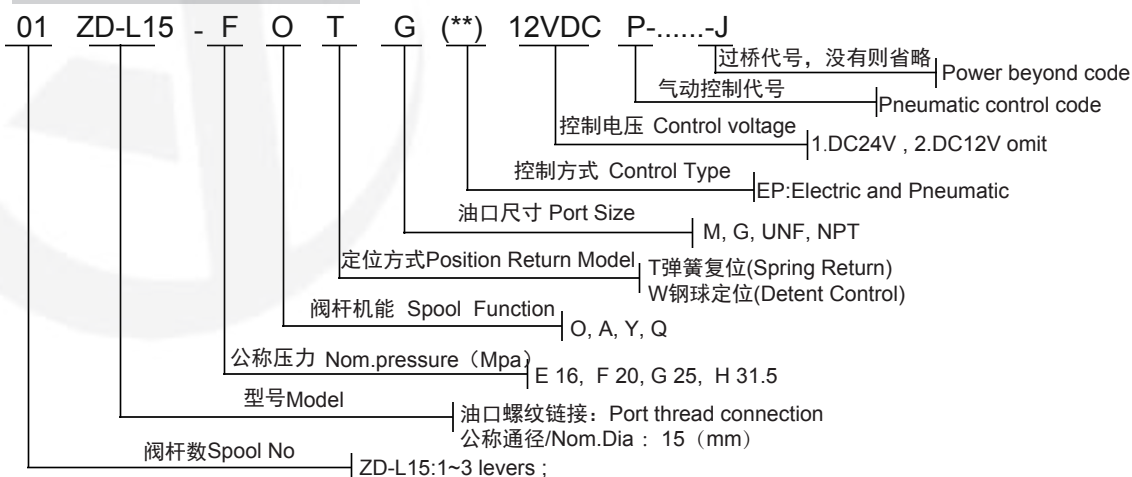

注：订货有特殊要求者，请与您的销售代表联系。
Notes: Special features not listed can often be made to your specifications, Please consult your sales representative.

ZD-L15电气控系列整体阀

ZD-L15 Series Electric and Pneumatic Directional Control Valves

ZD-L15外形安装连接尺寸 / MODEL ZD-L15 DIMENSIONAL DATA

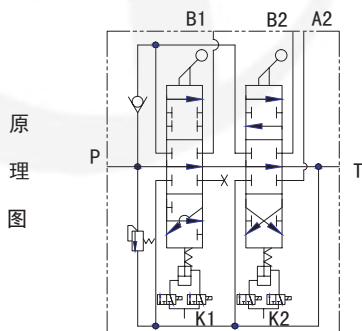
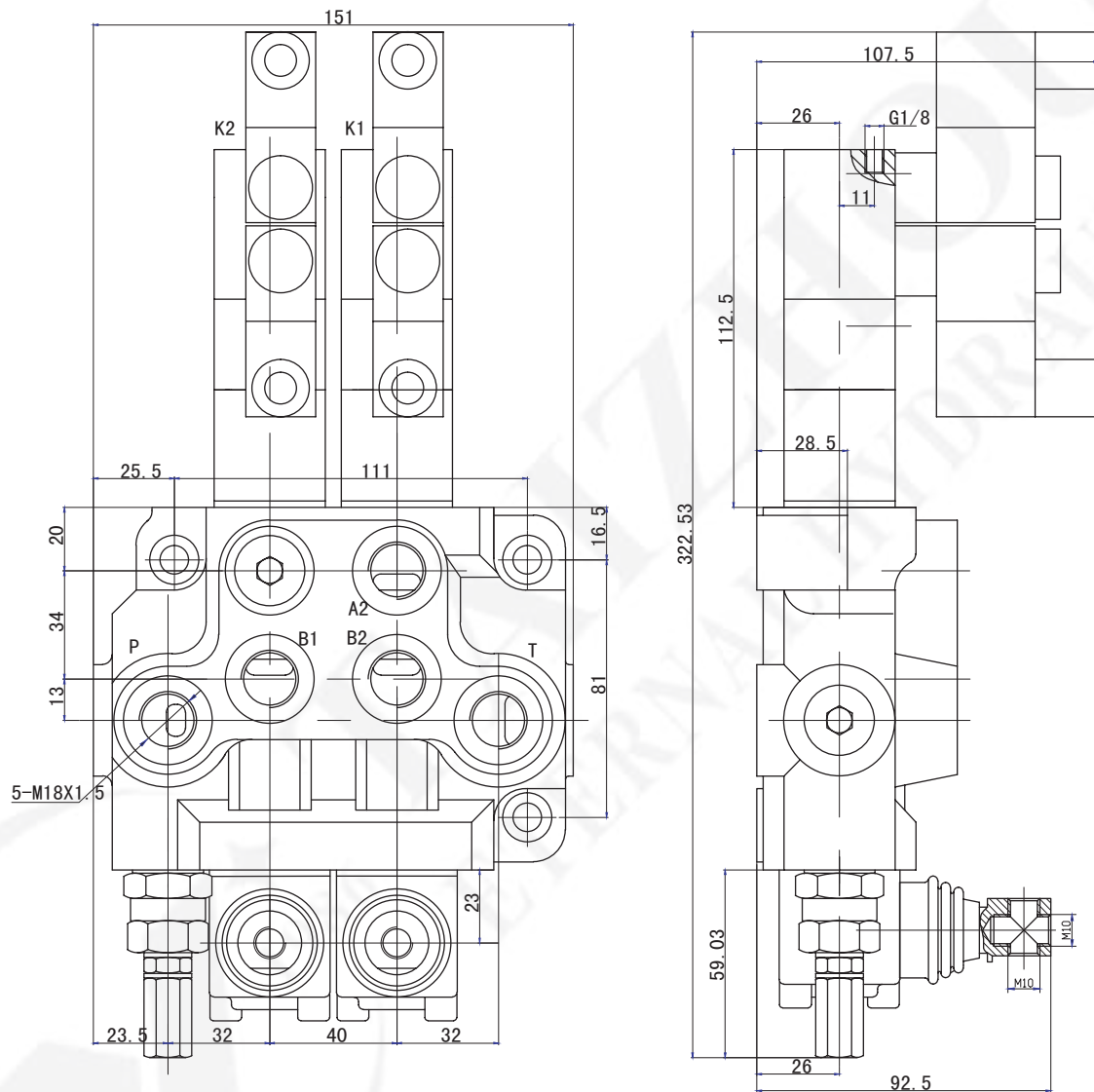

技术参数:

1. 公称通径: 15mm
2. 公称压力: 16MPa,
3. 最大流量: 60L/min.

ZDa-L15系列整体阀

ZDa-L15 Series Monoblock Directional Control Valves.

用途与特征/APPLICATIONS&FEATURES

ZDa-L15多路换向阀是我单位自主设计开发的一种中高压整体式多路换向阀。可按客户要求可在阀上设溢流阀、单向阀。溢流阀可调节系统压力，单向阀防止油液倒流，换向阀滑阀机能有关A、O、Y、P等，可任意组合。换向手柄有两种安装形式，便于不同方向的操作，该阀采用并联油路，设计有压力出口与其它液压元件相接提供动力源。经过特殊设计的密封方式，使阀的密封性能卓越。该阀广泛用于叉车、环卫车辆、小型装载机等工程机械的液压系统。

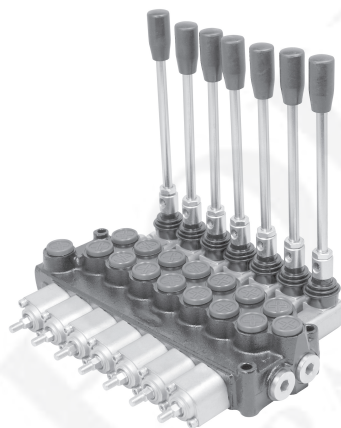

Model ZDa-L15 with middle-high pressure monoblock construction is an independently developed control valves by our company.

- ◆ Inner check valve: The check valve inside the valve body is to insure the hydraulic oil not to be returned.
- ◆ Inner relief valve: The relief valve inside the valve body is able to adjust the hydraulic system working pressure.
- ◆ Oil way: Parallel circuit, power beyond option
- ◆ Control Way: Manual control, pneumatic control, hydraulic and electric control for optional.
- ◆ Valve construction: monoblock construction, 1-7 levers.
- ◆ Spool Function: O, Y, P, A.
- ◆ The valve is widely used in the hydraulic system of forklift, environment vehicle and light loading machines.

性能参数/SPECIFICATIONS

公称压力 Nominal Pressure (Mpa)	最大压力 Max. pressure (Mpa)	公称流量 Nom. flow (L/min)	允许背压 Allowable Back. pressure (Mpa)	工作油液 Hydraulic Oil		
				温度范围 Tem.range (°C)	粘度范围 Visc.range (mm ² /s)	过滤精度 Filtrating accuracy (μm)
16	31.5	63	≤ 1	-20~+80	10~400	≤ 10

注：油液最高污染等级：按GB/T14039之19/16

Note: maximum permissible degree of contamination of the oil is according to GB/T14039-19/16

ZDa-L15系列整体阀

ZDa-L15 Series Monoblock Directional Control Valves.

型号说明/MODEL CODE

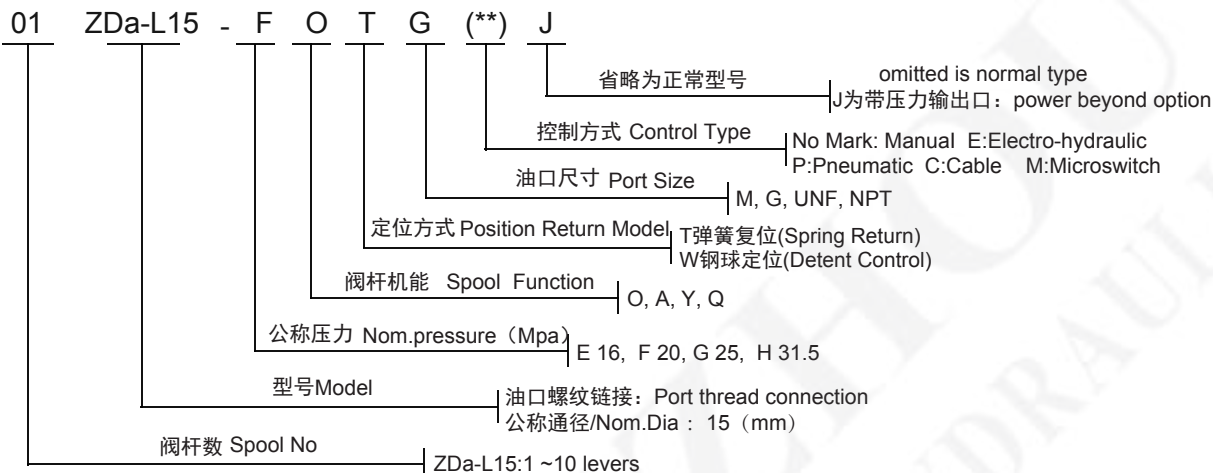

注: 订货有特殊要求者, 请与销售顾问联系。
Note: Special features not listed can often be made to your specifications. Please consult your sales representative.

ZDa-L15外形安装连接尺寸/MODEL ZDa-L15 DIMENSIONAL DATA

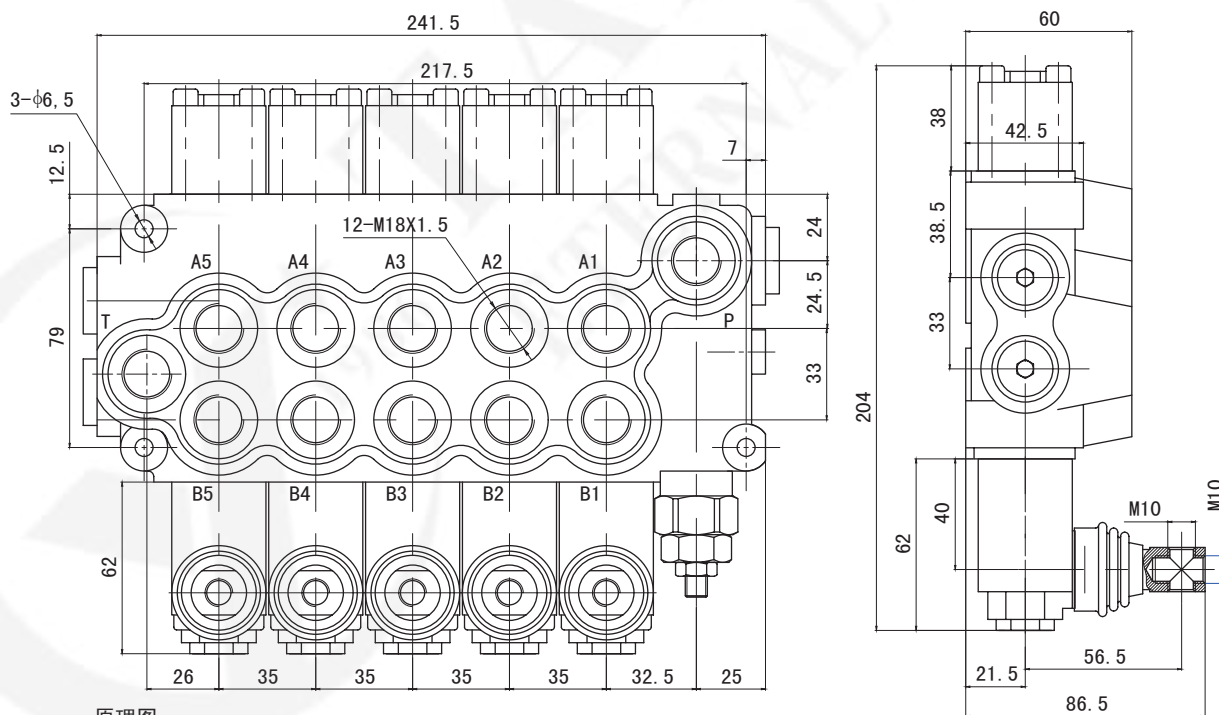

原理图

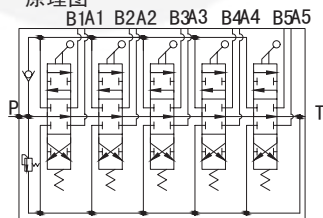

技术参数:

1. 公称通径 15mm
2. 公称压力 20MPa
3. 最大流量 63L/min

ZDa-L15气控系列多路阀

ZDa-L15 Pneumatic Control Valve

产品描述/SPECIFICATION

ZDa-L15气控系列多路阀是在ZDa-L15手动控制系列的基础上改进而来。它主要是改变了手动换向阀的操纵机构，在手动的基础上增加了气动控制，能够更好地实现远程控制。ZDa-L15系列多路阀的回油端设置了压力输出口，可与其他液压元件串联使用。该阀为整体式，具有结构紧凑，工作压力高，性能好，工作可靠，可实现多个执行机构的近、远程控制的优点。该阀广泛应用于工程机械、环卫机械、矿山机械和其他机械的液压系统。



产品特点/FEATURES

- ◆ 内置单向阀：阀体内置单向阀，防止油液倒流
- ◆ 内置安全阀：阀体内置溢流阀，可调节控制系统压力
- ◆ 油路形式：并联油路，带压力输出口
- ◆ 控制方式：气控换向，也可手动换向
- ◆ 阀体结构：整体结构，1-7联任意组合
 - ◆ 阀杆机能：O、A、Y等
 - ◆ Inner check valve: The check valve inside the valve body to insure the hydraulic oil not to be returned.
 - ◆ Inner relief valve: The relief valve inside the valve body is able to adjust the hydraulic system working pressure.
 - ◆ Oil way: Parallel circuit, with power beyond.
 - ◆ Control Way: pneumatic control, manual control
 - ◆ Valve construction: monoblock construction, 1-7 levers are available to assembled as you requests.
 - ◆ Spool Function: O,A,Y etc.

型号说明/MODEL CODE

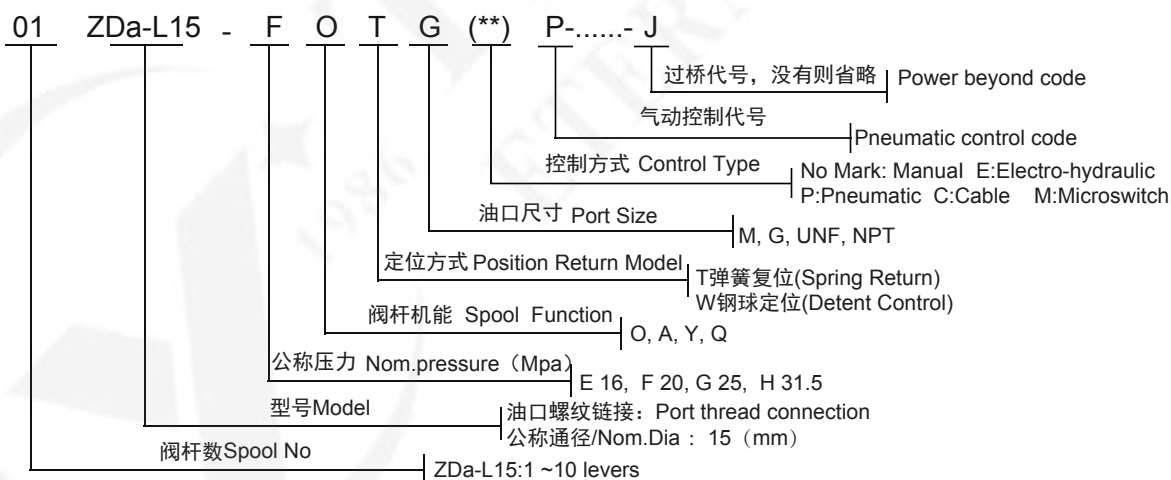

性能参数/SPECIFICATIONS

公称压力 (MPa) Nom. Pressure	最大压力 (MPa) Max. Pressure	公称流量 (L/min) Nom. Flow rate	最大流量 (L/min) Max. Flow rate	中位背压 (MPa) Back Pressure	工作油液hydraulic oil		
					温度范围 (℃) Tem.rang	粘度范围 (mm ² /S) Visc.rang	过滤精度 (μm) filtrating accuracy
20	31.5	50	60	≤1	-20 ~ +80	10 ~ 400	≤10

ZDa-L15气控系列多路阀

ZDa-L15 Pneumatic Control Valve

ZDa-L15 外形安装连接尺寸/MODEL ZDa-L15 DIMENSIONAL DATA

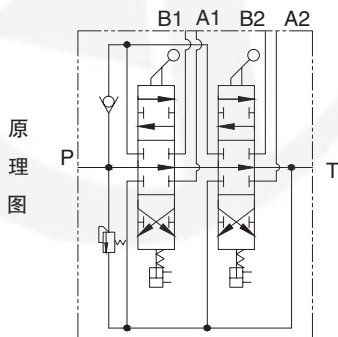
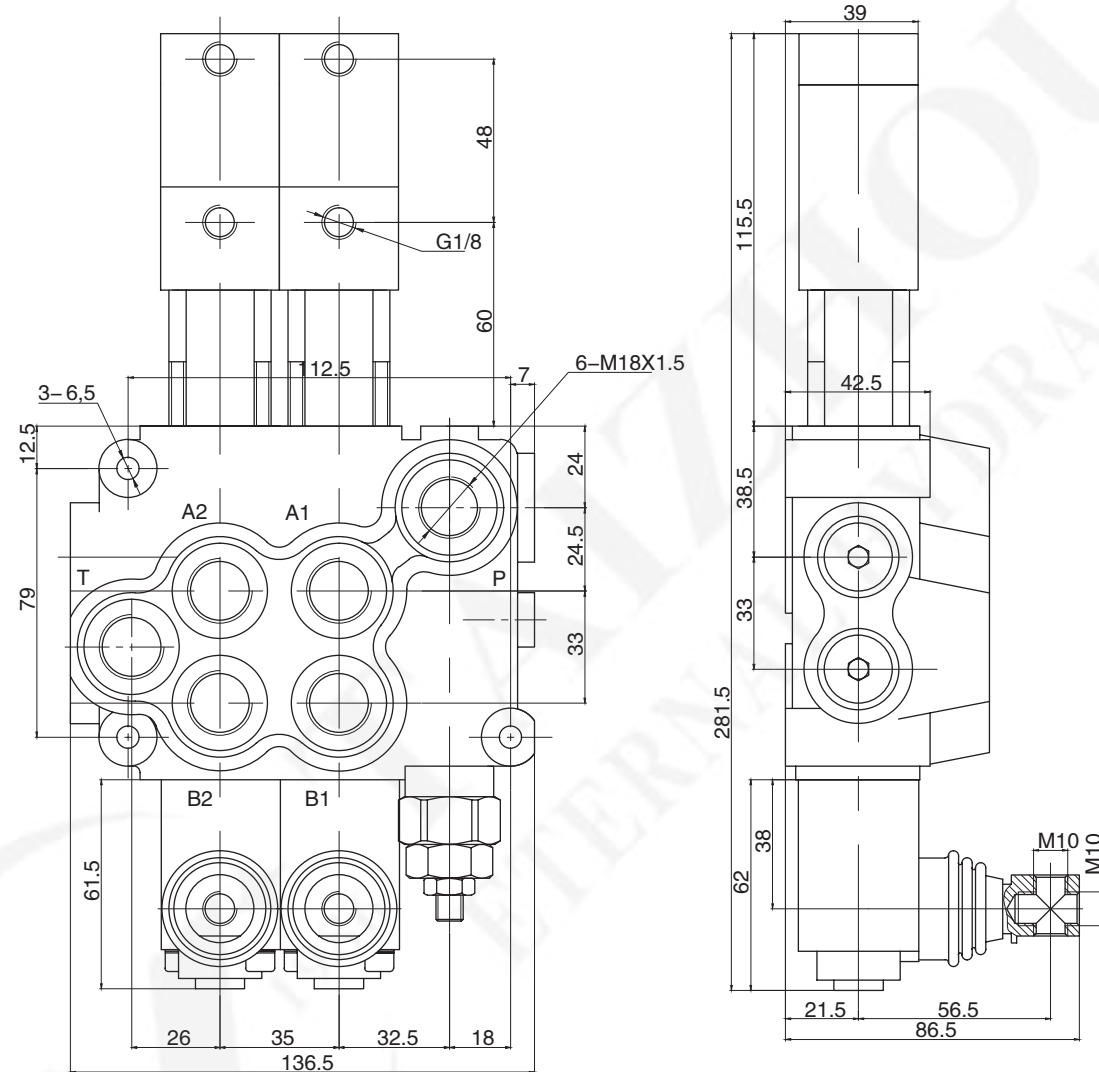

技术参数:

- 1.公称通径 15mm
- 2.公称压力 16MPa
- 3.公称流量 60L/min
- 4.工作气压 8Kg

注: 订货有特殊要求者, 请与销售顾问联系。

Note: Special features not listed can often be made to your specifications. Please consult your sales representative.

ZDa-L15电气控系列多路阀

ZDa-L15 Electric and Pneumatic Control Valve

产品描述/SPECIFICATION

ZDa-L15电气控系列多路阀是在ZDa-L15气控系列的基础上改进而来。它主要是改变了气控换向阀的操纵机构，在气控的基础上增加了电气控制，并且可以根据客户需求，安装无线遥控，能够更好地实现远程控制。该阀广泛应用于工程机械、环卫机械、矿山机械和其他机械的液压系统。

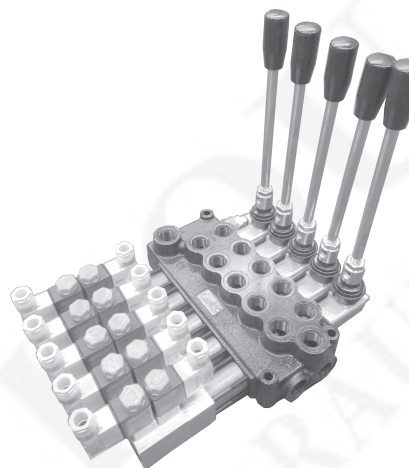

产品特点/FEATURES

- ◆ 内置单向阀：阀体内置单向阀，防止油液倒流
- ◆ 内置安全阀：阀体内置溢流阀，可调节控制系统压力
- ◆ 油路形式：并联油路，带压力输出口
- ◆ 控制方式：气控换向，也可手动换向
- ◆ 阀体结构：整体结构，1-7联任意组合
- ◆ 阀杆机能：O、A、Y等
- ◆ Inner check valve: The check valve inside the valve body to insure the hydraulic oil not to be returned.
- ◆ Inner relief valve: The relief valve inside the valve body is able to adjust the hydraulic system working pressure.
- ◆ Oil way: Parallel circuit, with power beyond.
- ◆ Control Way: pneumatic control, manual control
- ◆ Valve construction: monoblock construction, 1-7 levers are available to assembled as you requests.
- ◆ Spool Function: O,A,Y etc.

型号说明/MODEL CODE

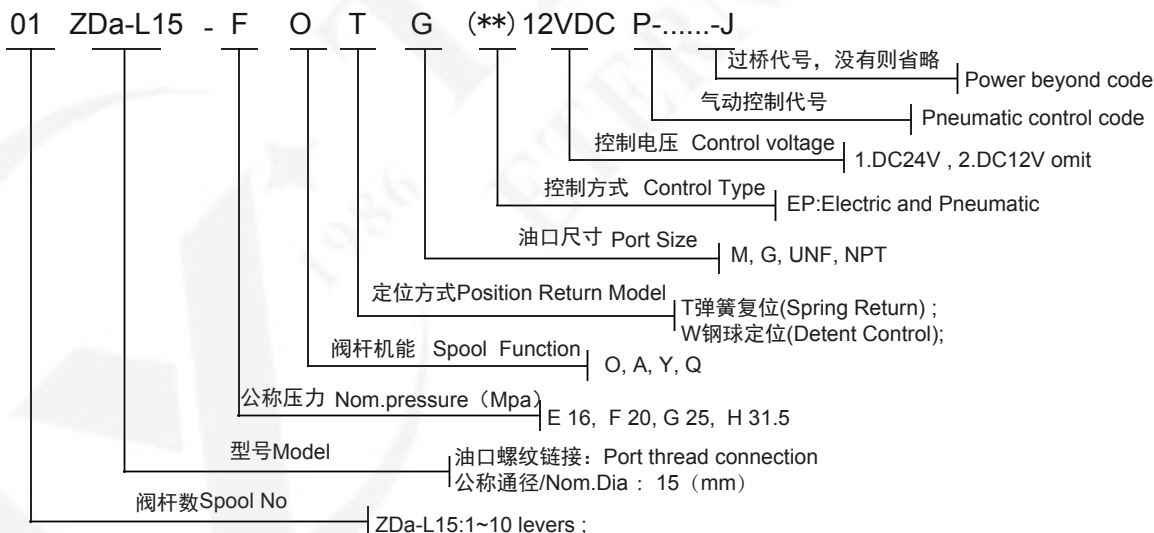

性能参数/SPECIFICATIONS

公称压力 (MPa) Nom. Pressure	最大压力 (MPa) Max. Pressure	公称流量 (L/min) Nom. Flow rate	最大流量 (L/min) Max. Flow rate	中位背压 (MPa) Back Pressure	工作油液 hydraulic oil		
					温度范围 (℃) Tem.rang	粘度范围 (mm ² /S) Visc.rang	过滤精度 (μm) filtrating accuracy
20	31	50	60	≤1	-20 ~ +80	10 ~ 400	≤10

ZDa-L15电气控系列多路阀

ZDa-L15 Electric and Pneumatic Control Valve

ZDa-L15 外形安装连接尺寸/MODEL ZDa-L15 DIMENSIONAL DATA

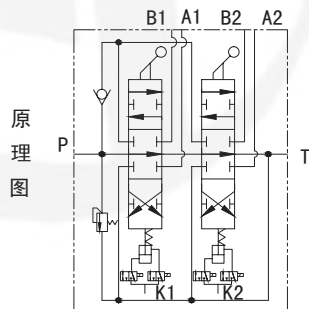
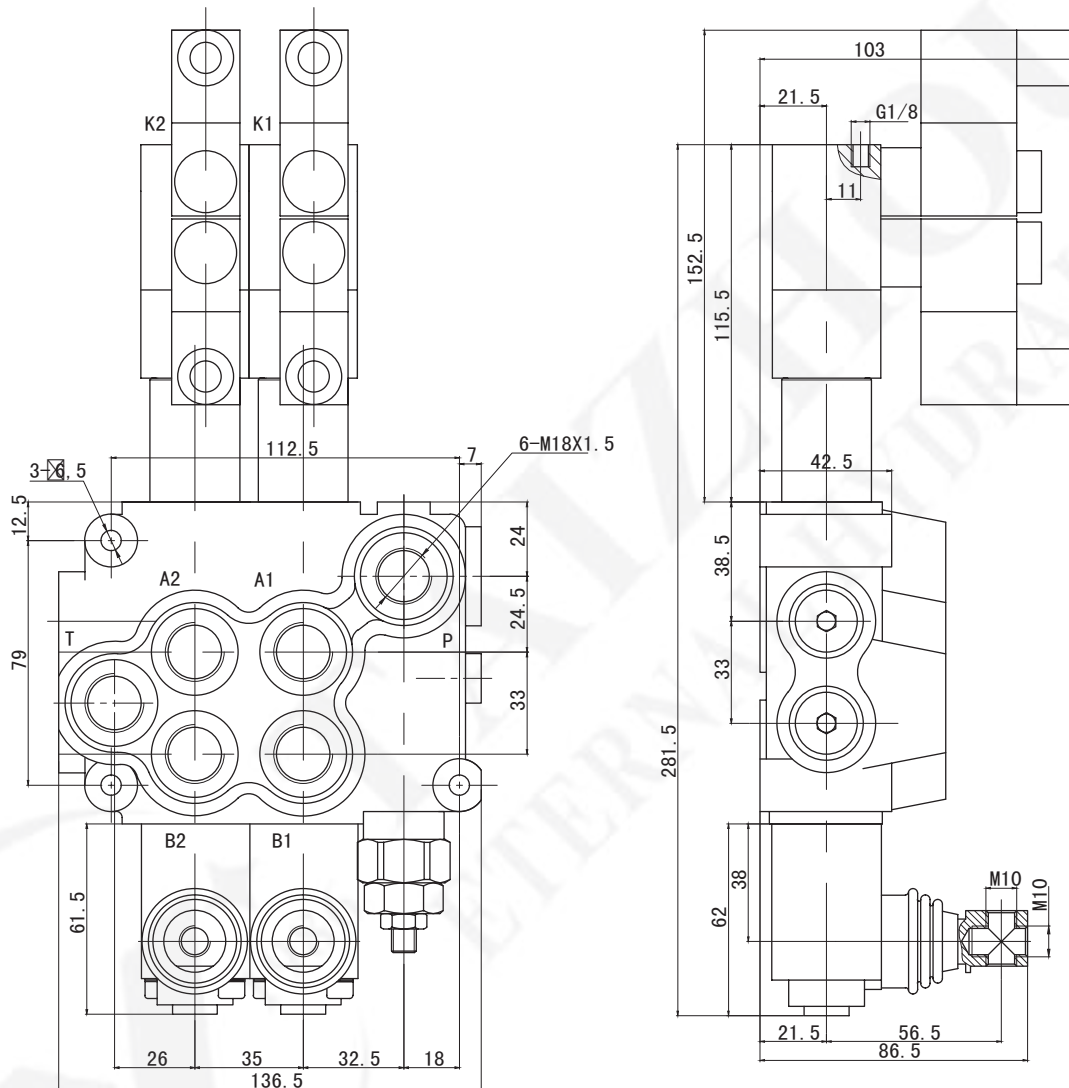

技术参数:

1. 公称通径 15mm
2. 公称压力 16MPa
3. 公称流量 60L/min
4. 工作气压 8Kg
5. 控制电压 DC12V

注: 订货有特殊要求者, 请与销售顾问联系。

Note: Special features not listed can often be made to your specifications. Please consult your sales representative.

ZDa-L15电液控系列多路阀

ZDa-L15 Electric and Hydraulic Control Valve

产品描述/SPECIFICATION

ZDa-L15电液控系列多路阀是在ZDa-L15电气控系列的基础上研发而来。它主要是在没有气源的情况下实现使用的电动控制，并且保留了原本的手动控制，从主油路上分流出一组控制油路，通过电磁阀来控制多路阀的换向工作，并且可以根据客户需求，安装无线遥控，能够更好地实现远程控制。该阀广泛应用于工程机械、环卫机械、矿山机械和其他机械的液压系统。

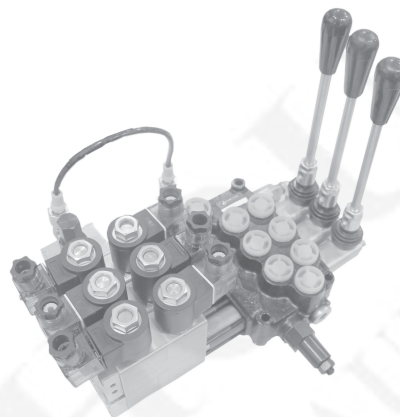

产品特点/FEATURES

- ◆ 内置单向阀：阀体内置单向阀，防止油液倒流
- ◆ 内置安全阀：阀体内置溢流阀，可调节控制系统压力
- ◆ 油路形式：并联油路，带压力输出口
- ◆ 控制方式：气控换向，也可手动换向
- ◆ 阀体结构：整体结构，1-7联任意组合
- ◆ 阀杆机能：O、A、Y等
- ◆ Inner check valve: The check valve inside the valve body to insure the hydraulic oil not to be returned.
- ◆ Inner relief valve: The relief valve inside the valve body is able to adjust the hydraulic system working pressure.
- ◆ Oil way: Parallel circuit, with power beyond.
- ◆ Control Way: hydraulic and electric control, manual control
- ◆ Valve construction: monoblock construction, 1-7 levers are available to assembled as you requests.
- ◆ Spool Function: O,A,Y etc.

型号说明/MODEL CODE

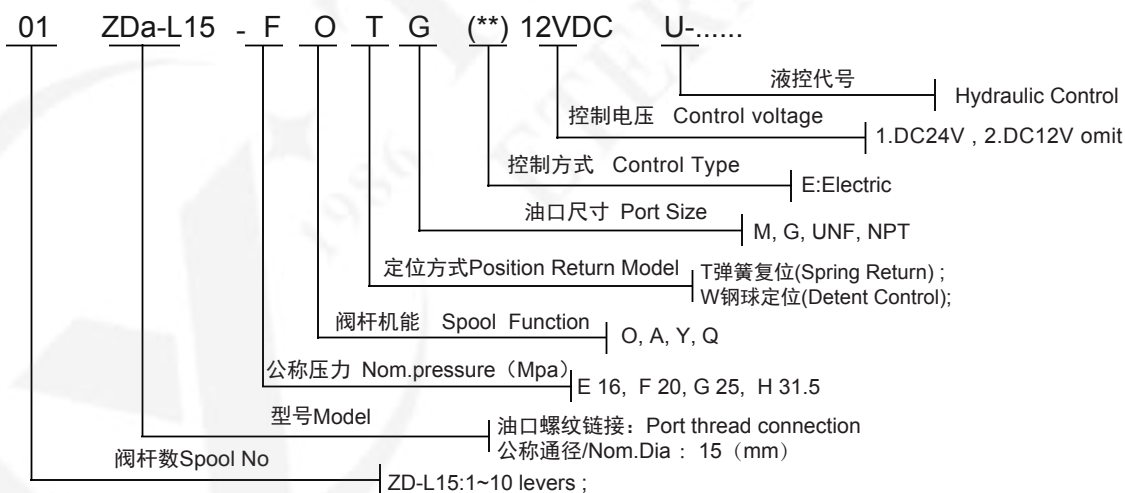

性能参数/SPECIFICATIONS

公称压力 (MPa) Nom. Pressure	最大压力 (MPa) Max. Pressure	公称流量 (L/min) Nom. Flow rate	最大流量 (L/min) Max. Flow rate	中位背压 (MPa) Back Pressure	工作油液hydraulic oil		
					温度范围 (℃) Tem.rang	粘度范围 (mm ² /S) Visc.rang	过滤精度 (μm) filtrating accuracy
20	31.5	50	60	≤2	-20 ~ +80	10 ~ 400	≤10

ZDa-L15电液控系列多路阀

ZDa-L15 Electric and Hydraulic Control Valve

ZDa-L15 外形安装连接尺寸/MODEL ZDa-L15 DIMENSIONAL DATA

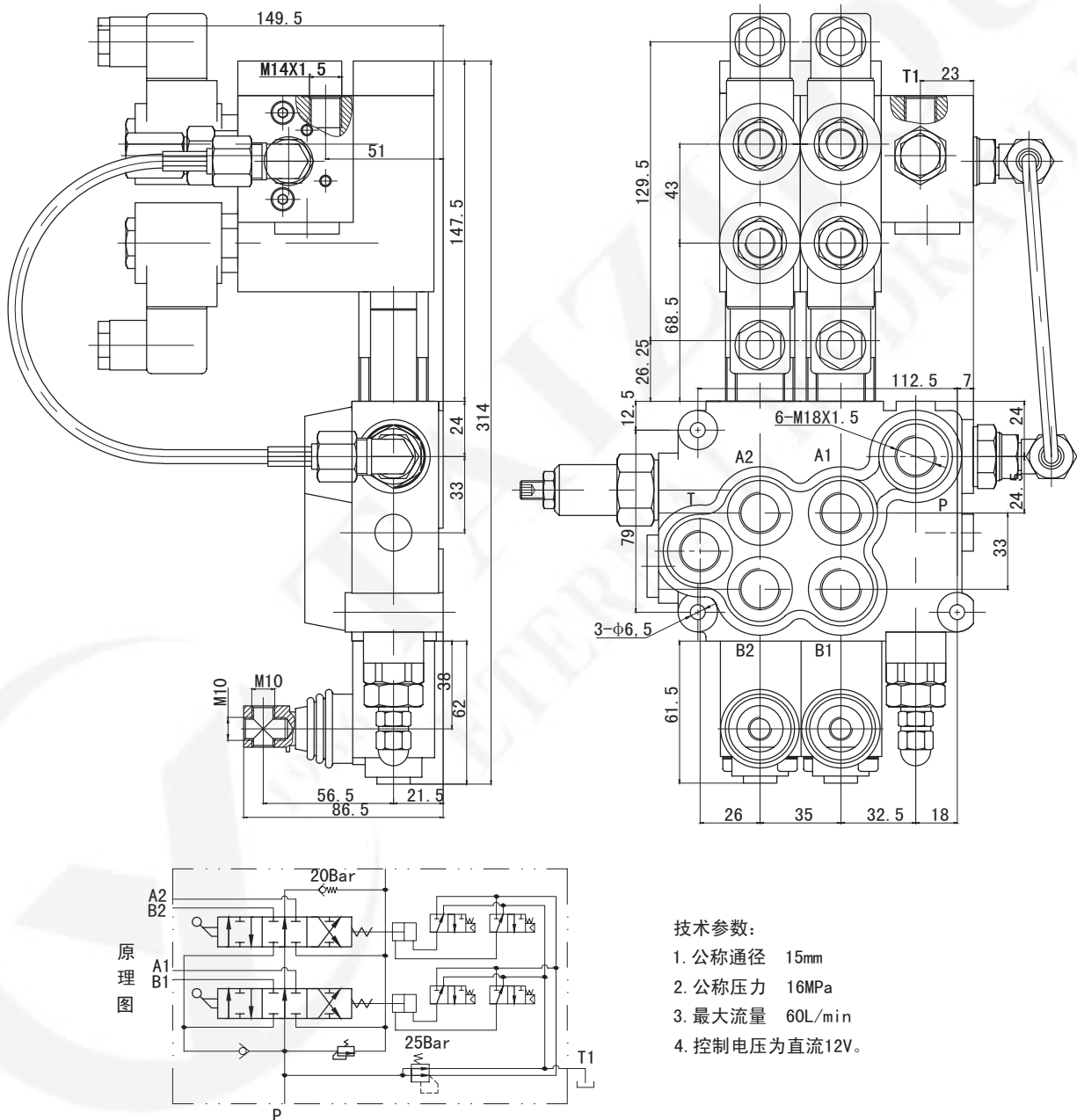

技术参数:

1. 公称通径 15mm
2. 公称压力 16MPa
3. 最大流量 60L/min
4. 控制电压为直流12V。

注: 订货有特殊要求者, 请与销售顾问联系。

Note: Special features not listed can often be made to your specifications. Please consult your sales representative.

ZT-L20系列整体阀

ZT-L20 Series Monoblock Directional Control Valves.

用途与特征/APPLICATIONS&FEATURES

ZT-L20多路换向阀是我单位自主设计开发的一种中高压整体式多路换向阀。可按客户要求可在阀上设溢流阀、单向阀、液压锁。溢流阀可调节系统压力，单向阀防止油液倒流，换向阀滑阀机能可有A、O、Y、P等，可任意组合，换向手柄有两种安装形式，便于不同方向的操作，该阀采用并联油路，设计有压力出口与其它液压元件相接提供动力源。经过特殊设计的密封方式，使阀的密封性能卓越。该阀广泛用于叉车、环卫车辆、小型装载机等工程机械的液压系统。

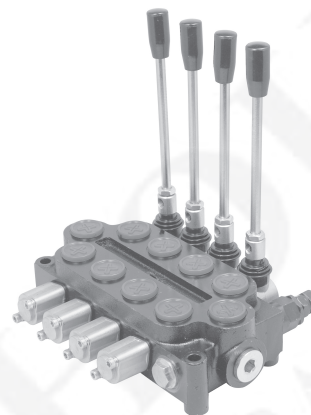

Model ZT-L20 with middle-high pressure monoblock construction is an independently developed control valves by our company.

- ◆ Inner check valve: The check valve inside the valve body is to insure the hydraulic oil not to be returned.
- ◆ Inner relief valve: The relief valve inside the valve body is able to adjust the hydraulic system working pressure.
- ◆ Oil way: Parallel circuit, power beyond option
- ◆ Control Way: Manual control, pneumatic control, hydraulic and electric control for optional.
- ◆ Valve construction: monoblock construction, 1-5 levers.
- ◆ Spool Function: O, Y, P, A.
- ◆ Option: Hydraulic lock is available to be added on A and B port.
- ◆ The valve is widely used in the hydraulic system of forklift, environment vehicle and light loading machines.

性能参数/SPECIFICATIONS

公称压力 Nominal Pressure (Mpa)	最大压力 Max. pressure (Mpa)	公称流量 Nom. flow (L/min)	允许背压 Allowable Back. pressure (Mpa)	工作油液 Hydraulic Oil		
				温度范围 Tem.range (°C)	粘度范围 Visc.range (mm ² /s)	过滤精度 Filtrating accuracy (μm)
20	31.5	90	≤ 1	-20~+80	10~400	≤ 10

注：油液最高污染等级:按GB/T14039之19/16

Note: maximum permissible degree of contamination of the oil is according to GB/T14039-19/16

ZT-L20系列整体阀

ZT-L20 Series Monoblock Directional Control Valves.

型号说明/MODEL CODE

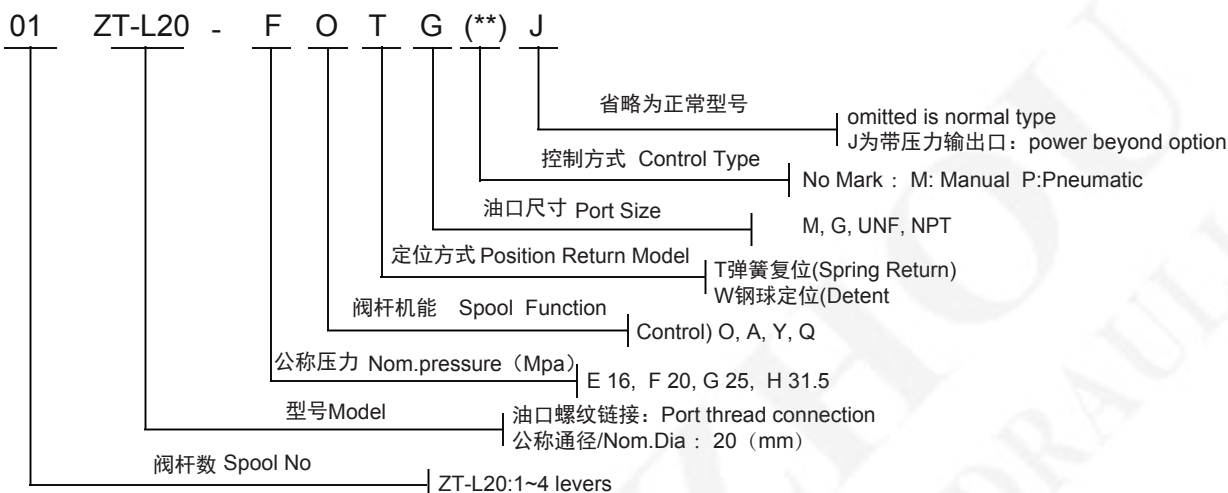

注: 订货有特殊要求者, 请与销售顾问联系。

Note: Special features not listed can often be made to your specifications. Please consult your sales representative.

ZT-L20 外形安装连接尺寸/MODEL ZT-L20 DIMENSIONAL DATA

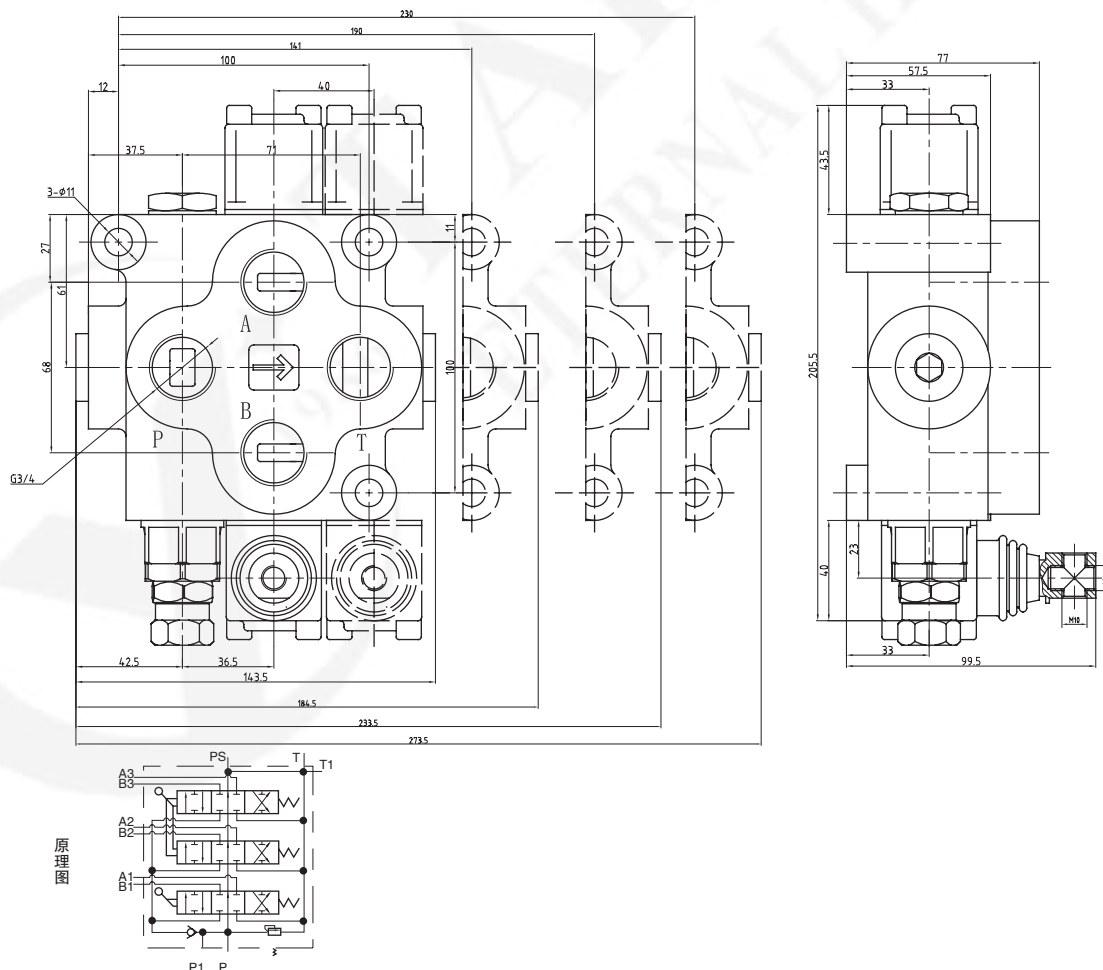

ZT-L20气控系列多路阀

ZT-L20 Pneumatic Control Valve

用途与特征/APPLICATIONS&FEATURES

ZT-L20气控系列多路阀是在ZT-L20手动控制系列的基础上改进而来。它主要是改变了手动换向阀的操纵机构，在手动的基础上增加了气动控制，能够更好地实现远程控制。ZT-L20系列多路阀的回油端设置了压力输出口，可与其他液压元件串联使用。该阀为整体式，具有结构紧凑，工作压力高，性能好，工作可靠，可实现多个执行机构的近、远程控制的优点。根据用户需要，换向阀的操纵机构可以和普通手动控制进行任意组合。该阀广泛应用于工程机械、环卫机械、矿山机械和其他机械的液压系统。



ZT-L20 series pneumatic control valves are developed on ZT-L20 manual control valves. It changed the control way of these valves, especially, it can be controlled by remote control with the pneumatic control way. The power beyond function is on the ZT-L20 series, it is able to be connected with other hydraulic valves in series. The features of this monoblock construction ZT-L20 pneumatic control valves are compact construction, high working pressure, better working performance, reliable working, remote controlling and etc. Besides that, the manual control can be used with the pneumatic control together. The valves are widely used on mechanical machines, sanitation machines, mining machines and other machines' hydraulic systems.

- ◆ 内置单向阀：阀体内置单向阀，防止油液倒流
Inner check valve: The check valve inside the valve body is to insure the hydraulic oil not to be returned.
- ◆ 内置安全阀：阀体内置溢流阀，可调节控制系统压力
Inner relief valve: The relief valve inside the valve body is able to adjust the hydraulic system working pressure.
- ◆ 油路形式：并联油路，带压力输出口
Oil way: Parallel circuit, with power beyond.
- ◆ 控制方式：气控换向，也可手动换向
Control Way: pneumatic control, manual control
- ◆ 阀体结构：整体结构，1-5联任意组合
Valve construction: monoblock construction, 1-5 levers are available to assembled as you requests.
- ◆ 阀杆机能：O、A、Y等
Spool Function: O,A,Y etc.

型号说明/MODEL CODE

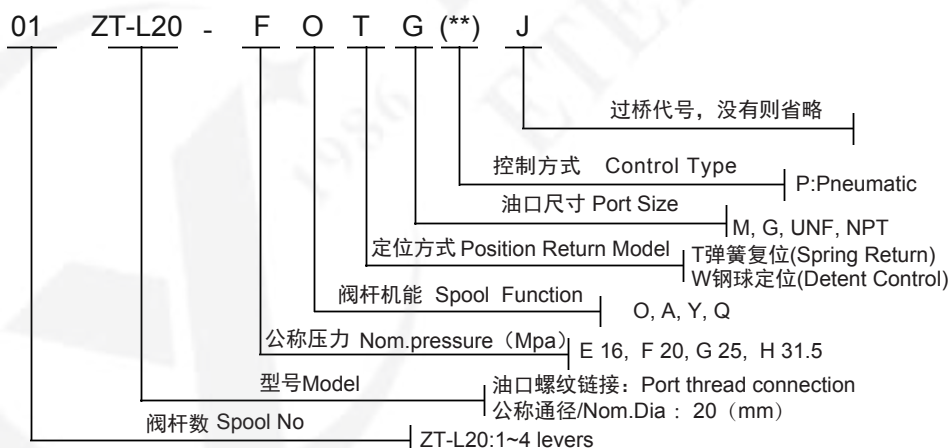

性能参数/SPECIFICATIONS

公称压力 (MPa) Nom. Pressure	最大压力 (MPa) Max. Pressure	公称流量 (L/min) Nom. Flow rate	最大流量 (L/min) Max. Flow rate	中位背压 (MPa) Back Pressure	工作油液hydraulic oil		
					温度范围 (℃) Tem.rang	粘度范围 (mm ² /S) Visc.rang	过滤精度 (μm) filtrating accuracy
20	31.5	80	100	≤1	-20 ~ +80	10 ~ 400	≤10

ZT-L20气控系列多路阀

ZT-L20 Pneumatic Control Valve

ZT-L20 外形安装连接尺寸/MODEL ZT-L20 DIMENSIONAL DATA

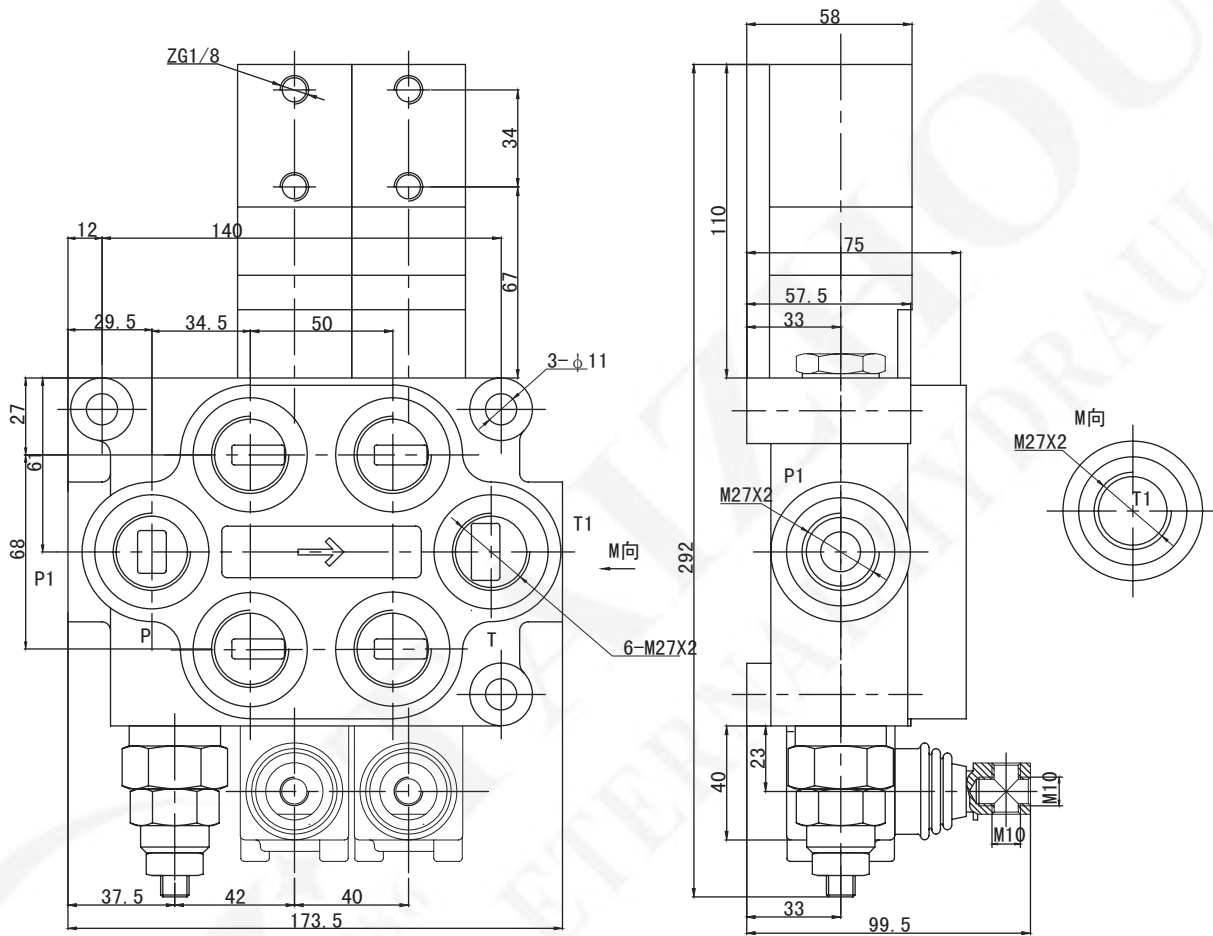

原理图

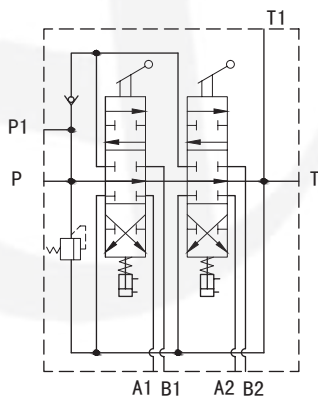

技术参数:

1. 公称压力: 16MPa,
2. 最大流量: 80L/min

注: 订货有特殊要求者, 请与销售顾问联系。

Note: Special features not listed can often be made to your specifications. Please consult your sales representative.

ZT-L20电气控系列多路阀

ZT-L20 Electric and Pneumatic Control Valve

产品描述/SPECIFICATION

ZT-L20电气控制系列多路阀是在ZT-L20气控系列的基础上改进而来。它主要是改变了气控换向阀的操纵机构，在气控的基础上增加了电气控制，并且可以根据客户需求，安装无线遥控，能够更好地实现远程控制。该阀广泛应用于工程机械、环卫机械、矿山机械和其他机械的液压系统。

产品特点/FEATURES

- ◆ 内置单向阀：阀体内置单向阀，防止油液倒流
- ◆ 内置安全阀：阀体内置溢流阀，可调节控制系统压力
- ◆ 油路形式：并联油路，带压力输出口
- ◆ 控制方式：气控换向，也可手动换向
- ◆ 阀体结构：整体结构，1-5联任意组合
- ◆ 阀杆机能：O、A、Y等
- ◆ Inner check valve: The check valve inside the valve body to insure the hydraulic oil not to be returned.
- ◆ Inner relief valve: The relief valve inside the valve body is able to adjust the hydraulic system working pressure.
- ◆ Oil way: Parallel circuit, with power beyond.
- ◆ Control Way: electric and pneumatic control, manual control
- ◆ Valve construction: monoblock construction, 1-5 levers are available to be assembled as you requests.
- ◆ Spool Function: O,A,Y etc.

型号说明/MODEL CODE

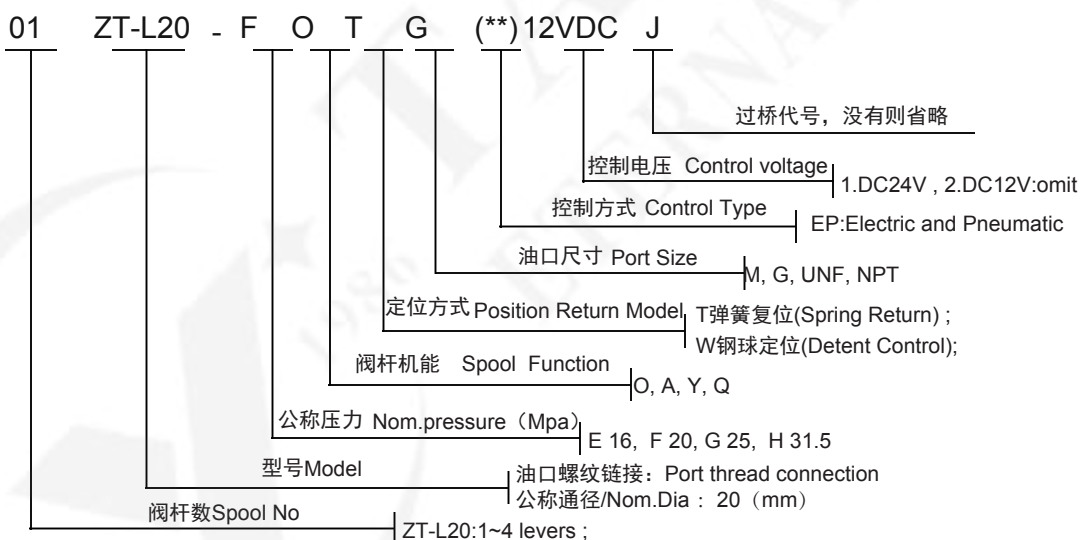

性能参数/SPECIFICATIONS

公称压力 (MPa) Nom. Pressure	最大压力 (MPa) Max. Pressure	公称流量 (L/min) Nom. Flow rate	最大流量 (L/min) Max. Flow rate	中位背压 (MPa) Back Pressure	工作油液hydraulic oil		
					温度范围 (℃) Tem.rang	粘度范围 (mm ² /S) Visc.rang	过滤精度 (μm) filtrating accuracy
20	31.5	80	100	≤1	-20 ~ +80	10 ~ 400	≤10

ZT-L20电气控系列多路阀

ZT-L20 Series Electric and Pneumatic Directional Control Valves

ZT-L20 Electric and Pneumatic Control Valve

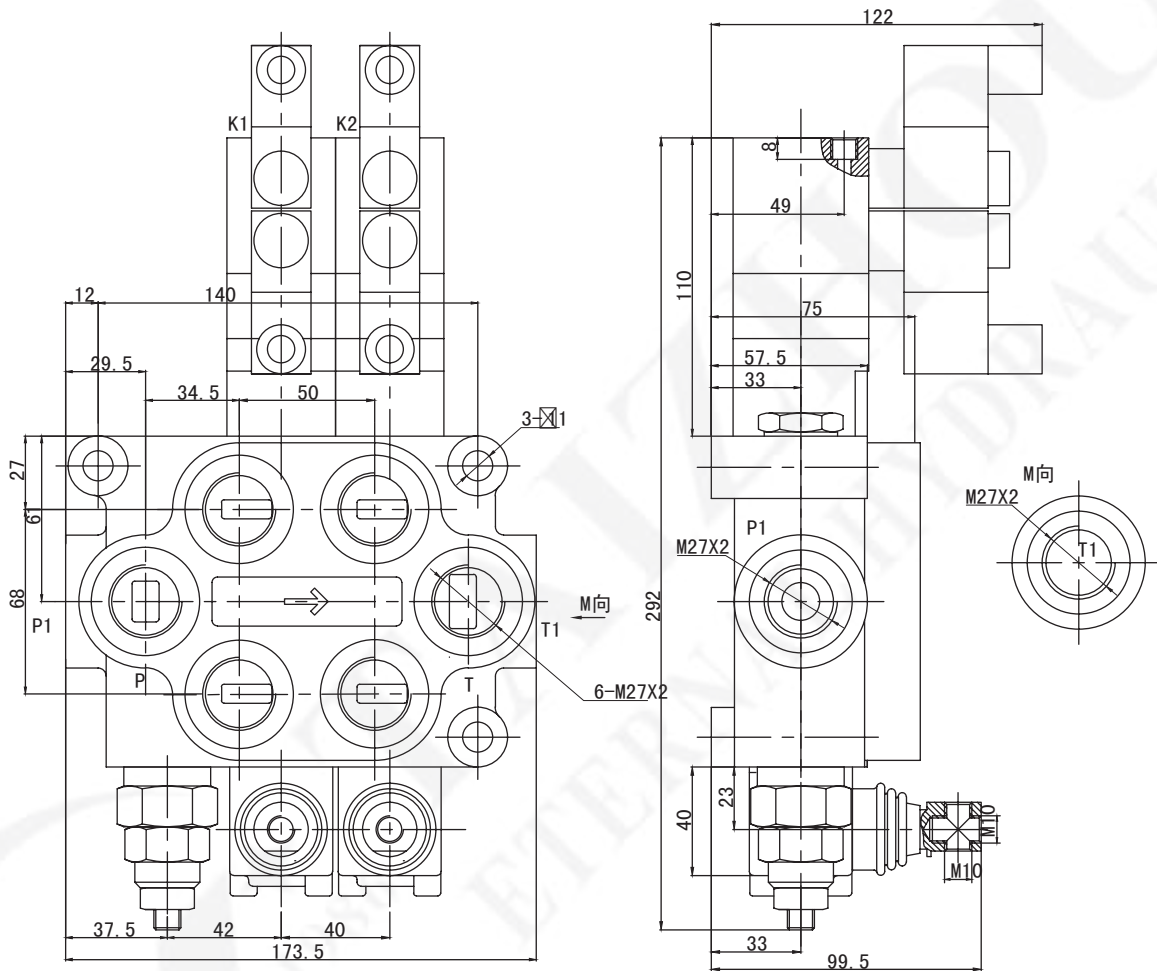

原理图

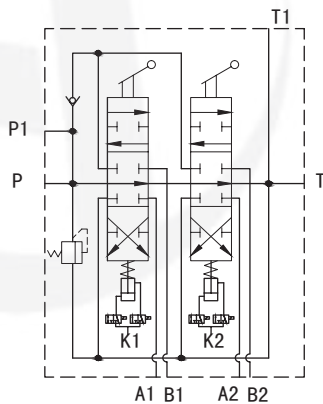

技术参数:

1. 公称压力: 16MPa,
2. 最大流量: 80L/min,
3. 控制电压DC12V/DC24V.

注: 订货有特殊要求者, 请与销售顾问联系。

Note: Special features not listed can often be made to your specifications. Please consult your sales representative.

More Series of Hydraulic Directional Control Valve:

www.xjetl.com/download/directional-valve-download

S Sectional Valve

Item	Pressure (Mpa)	Flow (L/min)	Spool No.	Spool Function	Position Return Model	Port Size	Control Type
P40 Series	E16Mpa F20Mpa G25Mpa H31.5Mpa	40	1-7	O,A,Y,Q	T:Spring Return W:Detent Control	M G UNF NPT	Electro-hydraulic Pneumatic Cable Solenoid Manual Microswitch
P40 Microswitch Series	E16Mpa F20Mpa G25Mpa H31.5Mpa	40	1-7	O,A,Y,Q	T:Spring Return W:Detent Control	M G UNF NPT	
P80 Series	E16Mpa F20Mpa G25Mpa H31.5Mpa	80	1-6	O,A,Y,Q	T:Spring Return W:Detent Control	M G UNF NPT	
P120 (SD18) Series	E16Mpa F20Mpa G25Mpa H31.5Mpa	120	1-4	O,A,Y,Q	T:Spring Return W:Detent Control	M G UNF NPT	Manual
Z50 Series	E16Mpa F20Mpa G25Mpa H31.5Mpa	50	1-7	O,A,Y,Q	T:Spring Return W:Detent Control	M G UNF NPT	Solenoid
Z80 Series	E16Mpa F20Mpa G25Mpa H31.5Mpa	50	1-6	O,A,Y,Q	T:Spring Return W:Detent Control	M G UNF NPT	
ZT(ZD)-L12 Series	E16Mpa F20Mpa G25Mpa H31.5Mpa	50	1-8	O,A,Y,Q	T:Spring Return W:Detent Control	M G UNF NPT	Electro-hydraulic Pneumatic Cable Manual Microswitch
ZT(ZD)-L15 Series	E16Mpa F20Mpa G25Mpa H31.5Mpa	60	1-3	O,A,Y,Q	T:Spring Return W:Detent Control	M G UNF NPT	
ZDa-L15 Series	E16Mpa F20Mpa G25Mpa H31.5Mpa	60	1-10	O,A,Y,Q	T:Spring Return W:Detent Control	M G UNF NPT	
ZT(ZD)-L20 Series	E16Mpa F20Mpa G25Mpa H31.5Mpa	100	1-4	O,A,Y,Q	T:Spring Return W:Detent Control	M G UNF NPT	Pneumatic Manual
ZT(ZD)-L102 (ZT-L10) Series	E16Mpa F20Mpa G25Mpa H31.5Mpa	40	1-6	O,A,Y,Q	T:Spring Return W:Detent Control	M G UNF NPT	Manual

Item	Pressure (Mpa)	Flow (L/min)	Spool No.	Spool Function	Position Return Model	Port Size	Control Type
SD4 Series	E16Mpa F20Mpa G25Mpa H31.5Mpa	40	1	O,A,Y,Q	T:Spring Return W:Detent Control	M G UNF NPT	Manual
SD5 Series	E16Mpa F20Mpa G25Mpa H31.5Mpa	45	1-6	O,A,Y,Q	T:Spring Return W:Detent Control	M G UNF NPT	Electro-hydraulic Pneumatic Solenoid Manual
SD11 Series	E16Mpa F20Mpa G25Mpa H31.5Mpa	70	1-4	O,A,Y,Q	T:Spring Return W:Detent Control	M G UNF NPT	
SD14 Series	E16Mpa F20Mpa G25Mpa H31.5Mpa	110	1	O,A,Y,Q	T:Spring Return W:Detent Control	M G UNF NPT	Manual
SD8 Series	E16Mpa F20Mpa G25Mpa H31.5Mpa	70	1-10	O,A,Y,Q	T:Spring Return W:Detent Control	M G UNF NPT	Electro-hydraulic Pneumatic Solenoid Manual
SD180 Series	E16Mpa F20Mpa G25Mpa H31.5Mpa	160	1-10	O,A,Y,Q	T:Spring Return W:Detent Control	M G UNF NPT	Pilot Control Pneumatic Manual
SD25 Series	E16Mpa F20Mpa G25Mpa H31.5Mpa	240	1-12	O,A,Y,Q	T:Spring Return W:Detent Control	M G UNF NPT	Manual
DCV40 Series	E16Mpa F20Mpa G25Mpa H31.5Mpa	40	1-8	O,A,Y,Q	T:Spring Return W:Detent Control	M G UNF NPT	Electro-hydraulic Pneumatic Cable Manual Microswitch
DCV80 Series	E16Mpa F20Mpa G25Mpa H31.5Mpa	100	1-4	O,A,Y,Q	T:Spring Return W:Detent Control	M G UNF NPT	
DCV60 Series	E16Mpa F20Mpa G25Mpa H31.5Mpa	50	1-12	O,A,Y,Q	T:Spring Return W:Detent Control	M G UNF NPT	Electro-hydraulic Pneumatic Manual
DCV100 Series	E16Mpa F20Mpa G25Mpa H31.5Mpa	90	1-14	O,A,Y,Q	T:Spring Return W:Detent Control	M G UNF NPT	

Item	Pressure (Mpa)	Flow (L/min)	Spool No.	Spool Function	Position Return Model	Port Size	Control Type
DCV140 Series	E16Mpa F20Mpa G25Mpa H31.5Mpa	130	1-14	O,A,Y,Q	T:Spring Return W:Detent Control	M G UNF NPT	Electro-hydraulic Pneumatic Manual
DCV200 Series	E16Mpa F20Mpa G25Mpa H31.5Mpa	180	1-14	O,A,Y,Q	T:Spring Return W:Detent Control	M G UNF NPT	Manual
ZS-L10 Series	E16Mpa F20Mpa G25Mpa H31.5Mpa	40	1-18	O,A,Y,Q	T:Spring Return W:Detent Control	M G UNF NPT	Manual
ZS-L20 Series	E16Mpa F20Mpa G25Mpa H31.5Mpa	100	1-15	O,A,Y,Q	T:Spring Return W:Detent Control	M G UNF NPT	
ZS-L25 Series	E16Mpa F20Mpa G25Mpa H31.5Mpa	160	1-12	O,A,Y,Q	T:Spring Return W:Detent Control	M G UNF NPT	
MB2 Series	E16Mpa F20Mpa G25Mpa H31.5Mpa	40	1	O,A,Y,Q	T:Spring Return W:Detent Control	M G UNF NPT	Manual
MB3 Series	E16Mpa F20Mpa G25Mpa H31.5Mpa	45	1-6	O,A,Y,Q	T:Spring Return W:Detent Control	M G UNF NPT	Electro-hydraulic Manual Pneumatic Hydraulic
MB5 Series	E16Mpa F20Mpa G25Mpa H31.5Mpa	70	1-6	O,A,Y,Q	T:Spring Return W:Detent Control	M G UNF NPT	Manual
RD5100/ RD5200/ RD5300 Series	E16Mpa F20Mpa G25Mpa H31.5Mpa	120	1-3	O,A,Y,Q	T:Spring Return W:Detent Control	M G UNF NPT	Manual
SVV90 Series	E16Mpa F20Mpa G25Mpa H31.5Mpa	90	1	O,A,Y,Q	T:Spring Return W:Detent Control	M G UNF NPT	Solenoid
LVA Series	E16Mpa F20Mpa G25Mpa H31.5Mpa	95	1	O,A,Y,Q	T:Spring Return W:Detent Control	M G UNF NPT	Manual

Item	Pressure (Mpa)	Flow (L/min)	Spool No.	Spool Function	Position Return Model	Port Size	Control Type
JYPM100 Series	E16Mpa F20Mpa G25Mpa H31.5Mpa	115	1	O,A,Y,Q	T:Spring Return W:Detent Control	M G UNF NPT	Manual
LKF Series	E16Mpa F20Mpa G25Mpa H31.5Mpa	30/ 60/ 114		O,A,Y,Q	T:Spring Return W:Detent Control	M G UNF NPT	

Mode Code

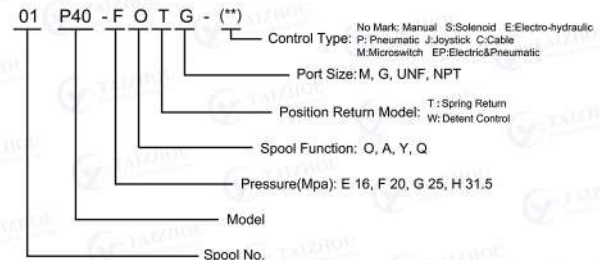

Spool Function Symbols



O Spool Function



Y Spool Function



A Spool Function



Q Spool Function

Port Size

Flow	M	G	UNF	NPT
≤60L	M18x1.5	G 3/8"	3/4-16 UNF	NPT 3/8"
60-80L	M22x1.5	G 1/2"	7/8-14 UNF	NPT 1/2"
100-140L	M27x2	G 3/4"	1-1/8-12 UNF	NPT 3/4"
140-160L	M33x2	G 1"	1-1/8-12 UNF	NPT 1"
160-240L	M42x2	G 1-1/2"	1-3/8-12 UNF	NPT 1-1/2"

If you need special dimension port size, please consult to our Engineer.