

## ■ 型号说明 Model Code



A7V 160 LV 1 L P F 0 0

辅助元件Auxiliary equipment: 0--无none

行程限位Stroke limiter:

0--无none

M--机械行程限位mechanically adjustable (for LV and DR)

H--液压行程限位stroke limiter, hydraulic (for LV)

油口连接 Pipe connections:

F: 压力油口Pressure port-- SAE法兰, 在侧面SAE flange, on side

吸油口 Suction port -- SAE法兰, 在侧面SAE flange, on side

G: 压力油口Pressure port-- 螺纹连接, 在侧面threaded, on side

吸油口 Suction port -- SAE法兰, 在侧面SAE flange, on side

轴伸 Shaft End: P--平键 keyed shaft GB1096-79

Z--花键 splined shaft DIN5480

S--花键 splined shaft GB3478.1-83

转向(从轴端看)Direction of rotation: R--顺时针clockwise; L--逆时针anti-clockwise

结构型式 Series: 规格Size 20-160 结构Series 1 规格Size 250-500 结构Series 5.1

变量方式 Control device:

LV--恒功率变量 Constant HP control MA--手动变量 Manual control

DR--恒压变量 Constant pressure control HD--液控变量 Hydraulic control

规格 Size: 20、28、40、55、58、80、78、107、117、160、250、355、500 ml/r

泵型号 Pump type: 斜轴式变量泵 Axial piston variable displacement pump

## ■ 结构剖视 Construction

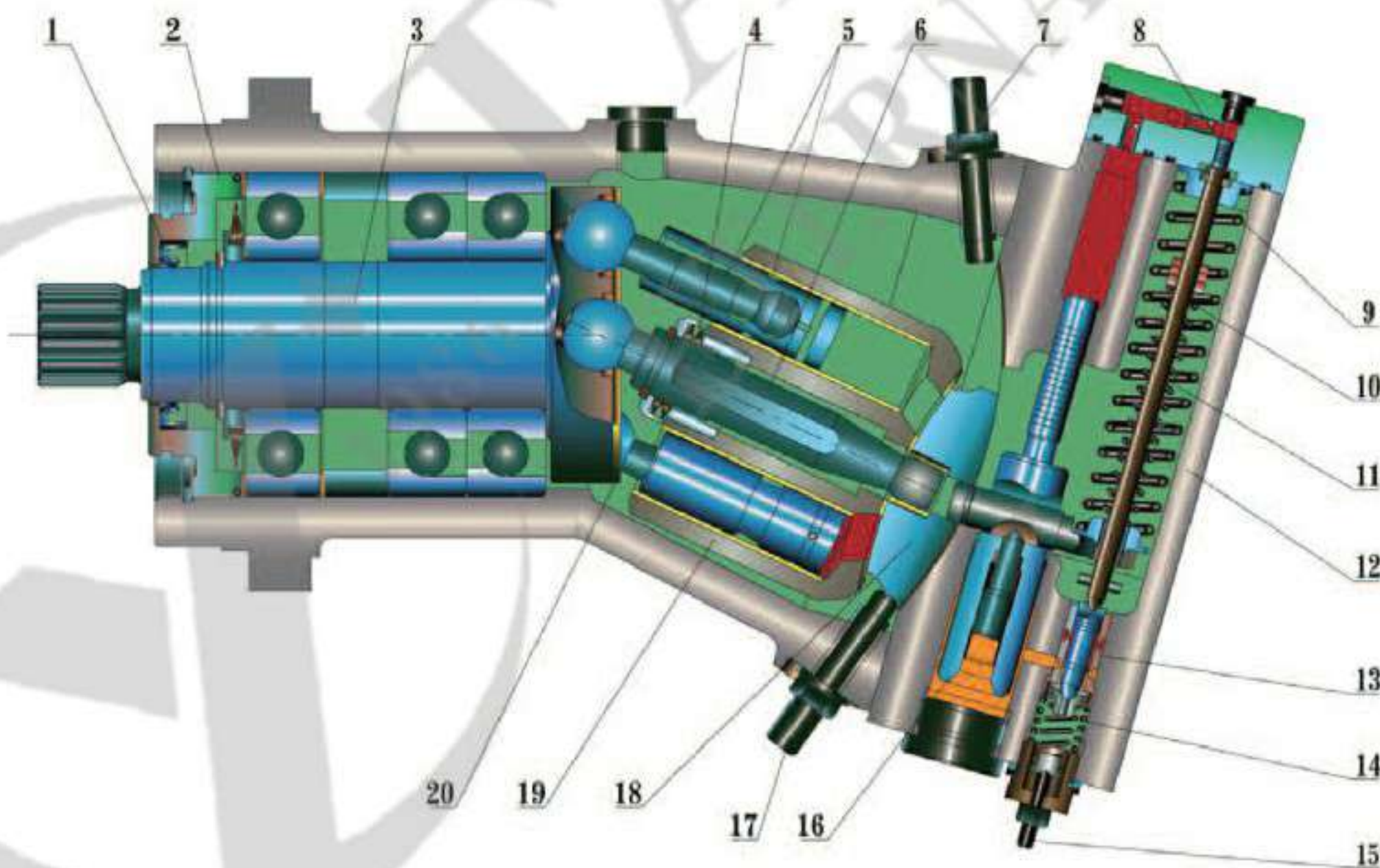

1. 骨架油封 Oil seal kit

2. 端盖 Front cover

3. 主轴 Shaft

4. 蝶形弹簧 Dishing Spring

5. 柱塞组件 Piston

6. 中心轴 Center pin

7. 小流量限位螺钉 Limiter screw

8. 先导活塞 Pilot piston

9. 大功率弹簧 Bigger power spring

10. 小功率弹簧 Smaller power spring

11. 顶杆 Control rod

12. 变量壳体 Regulator housing

13. 伺服活塞组件 Assembly parts

14. 起始变量调节弹簧 Adjusting spring

15. 起始变量调节螺钉 Adjusting screw

16. 变量活塞 Flow piston

17. 大流量限位螺钉 Limiter screw

18. 配油盘 Port plate

19. 缸体 Cylinder block

20. 回程盘 Retainer

## 外形尺寸 Dimension

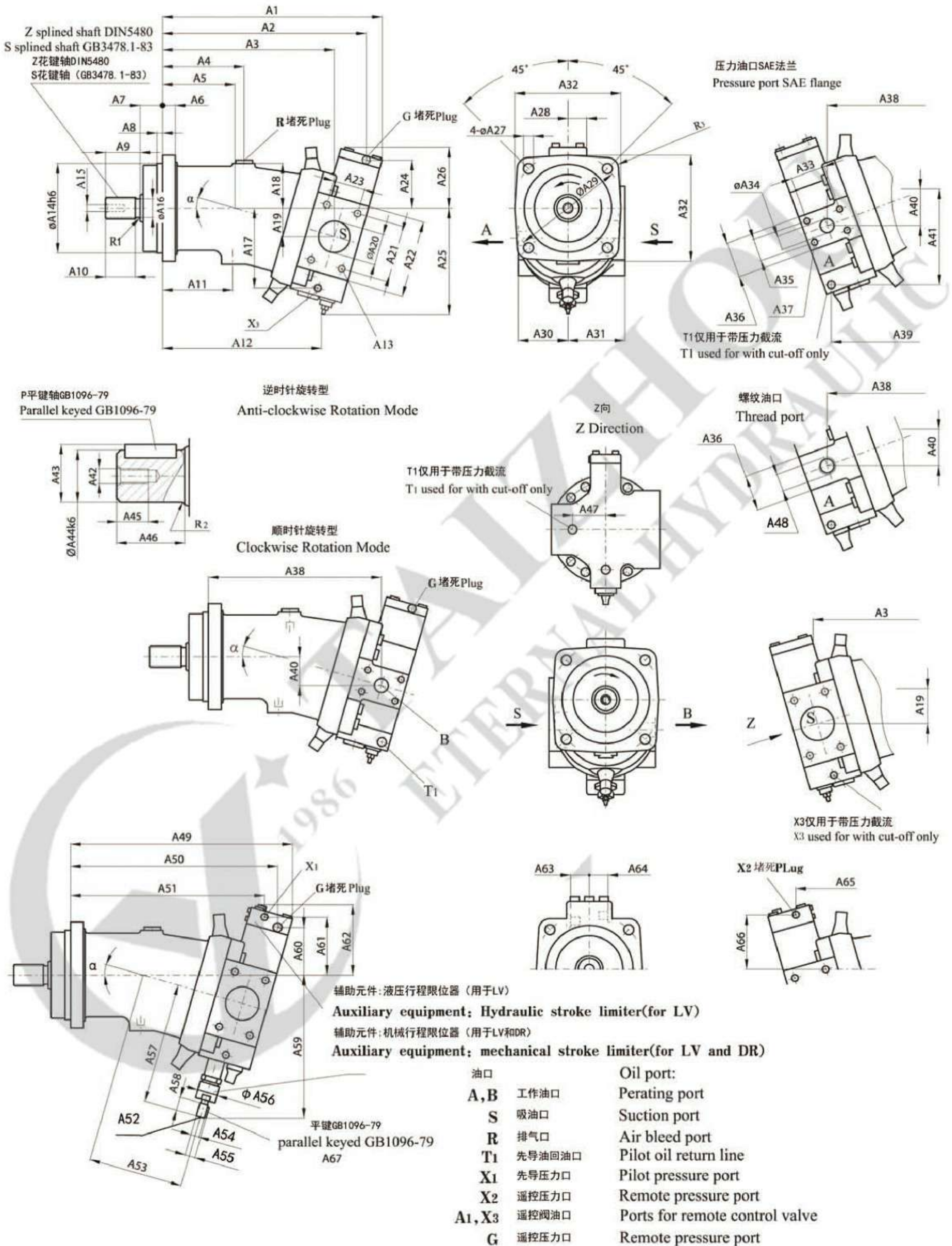

### ■ 元件外形尺寸 系列1 规格20~160 Unit Dimension Series 1 Size 20~160

规格 size	$\alpha^\circ$	A1	A2	A3	A4	A5	A6	A7	A8	A9	A10	A11	A12	A13	深 deep	A14	A15	A16	A17	A18	A19	A20
20	9	251	224	199	107	75	16	25	8	43	28	80	160	M12	20	100	M8	21.5	85	52	20	38
28	16	260	232	195	107	75	16	25	8	43	28	80	149	M12	20	100	M8	21.5	95	50	34	38
40	9	317	287	255	123	108	20	32	10	35	28	123	244	M12	20	125	M12	25	95	63	23	50
55	16	327	296	251	123	108	20	32	10	35	28	123		M12	20	125	M12	25		63	41	50
58	9	374	337	304	152	137	23	32	10	40	33	152	295	M12	18	140	M12	30	106	77	26.5	63
80	16	385	351	300	152	137	23	32	10	40	33	152		M12	18	140	M12	30		77	48	63
78	9	381	347	310	145	130	25	40	10	45	37.5	145	298	M12	17	160	M12	35	113	80	29	63
107	16	393	358	305	145	130	25	40	10	45	37.5	145		M12	17	160	M12	35		80	50	63
117	9	443	402	364	214	156	28	40	12	50	43	174.5	350	M16	24	180	M16	40	130	93	33	75
160	16	454	414	359	213	156	28	40	12	50	43	174.5		M16	24	180	M16	40		88	58	75

规格 size	A21	A22	A23	A24	A25	A26	A27	A28	A29	A30	A31	A32	A33	A34	A35	A36	A37	深 deep	A38	A39	A40	A41
20	69.9	94	35.7	78	132	95	11	23.5	125	58	58	118	50.8	19	23.8	46	M10	17	193		19	
28	69.9	94	35.7	59	145	80	11	23.5	125	58	58	118	50.8	19	23.8	46	M10	17	189		33	
40	77.8	102	42.9	87	166	109	13.5	29	160	71	81	150	50.8	19	23.8	53	M10	17	253	261	23	98
55	77.8	102	42.9	64	182	91	13.5	29	160	71	81	150	50.8	19	23.8	53	M10	17	249		40	
58	88.9	115	50.8	93	168	113	13.5	33	180	86	92	165	57.2	25	27.8	64	M12	18	301	313	26	109
80	88.9	115	50.8	68	194		13.5	33	180	86	92	165	57.2	25	27.8	64	M12	17	300		48	
78	88.9	115	50.8	101	180	120	17.5	34	200	89	93	190	57.2	25	27.8	64	M12	17	306	318	28	119
107	88.9	115	50.8	73	200	98	17.5	34	200	89	93	190	57.2	25	27.8	64	M12	17	301		49	
117	106.4	135	61.9	114	195	137	17.5	36	224	104	113	210	66.7	32	31.8	70	M14	19	359	369	32	136
160	106.4	135	61.9	83	212	112	17.5	36	224	104	113	210	66.7	32	31.8	70	M14	19	354		57	

规格 size	A42	A43	A44	A45	A46	A47	A48	A49	A50	A51	A52	深 deep	A53	A54	A55	A56	A57	A58	A59	A60	A61
20	M8	27.9	25	19	50	38	M27x2	257	226	230	M3	9	108	8	8.8	42	161	14	176	77	104
28	M8	27.9	25	19	50	38	M27x2	269	234	242	M3	9	108	8	8.8	42	161	14	186	58	84
40	M12	33	30	28	60	40	M33x2	323	290	279	M4	10	134	10	11.2		184	16	204	85	117
55	M12	33	30	28	60	40	M33x2	337	299	292	M4	10	134	10	11.2		184	16	215	62	98
58	M12	38	35	28	70	62	M42x2	378	344	330	M5	12	155.5	16	18	52	228	24	251	91	116
80	M12	38	35	28	70	62	M42x2	391	354	343	M5	12	155.5	16	18	52	228	24	265	65	91
78	M12	43	40	28	80	55	M42x2	385	352	338	M5	12	169	16	18	52	236	24	261	99	124
107	M12	43	40	28	80	55	M42x2	400	363	351	M5	12	169	16	18	52	236	24	276	71	98
117	M16	48.5	45	36	90	65	M48x2	445	408	384	M5	12.5	192	16	18	65	266	24	294	111	137
160	M16	48.5	45	36	90	65	M48x2	461	420	399	M5	12.5	192	16	18	65	266	24	310	79	108

规格 size	A62	A63	A64	A65	A66	平键 key A67 GB1096-79	平键 key GB1096-79	花键 spline DIN5480	花键 spline GB3478.1-83	R1	R2	R3
20	129	35	30	228	92	键 2x10	键 8x40	W25x1.25x18x9g	EXT18Zx1.25mx30Rx5f	1.2	0.8	12
28	114	35	30	238	73	键 2x10	键 8x40	W25x1.25x18x9g	EXT18Zx1.25mx30Rx5f	1.2	0.8	12
40	147	30	30	276	104	键 3x10	键 8x50	W30x2x14x9g	EXT14Zx2mx30Rx5f	1.6	1.5	16
55	128	30	30	288	83	键 3x10	键 8x50	W30x2x14x9g	EXT14Zx2mx30Rx5f	1.6	1.5	16
58	142	33	33	328	104	键 5x16	键 10x56	W35x2x16x9g	EXT16Zx2mx30Rx5f	1.6	1.6	16
80	120	33	33	339	80	键 5x16	键 10x56	W35x2x16x9g	EXT16Zx2mx30Rx5f	1.6	1.6	16
78	150	33	33	336	112	键 5x16	键 12x63	W40x2x18x9g	EXT18Zx2mx30Rx5f	2.5	1.6	20
107	126	33	33	348	86	键 5x16	键 12x63	W40x2x18x9g	EXT18Zx2mx30Rx5f	2.5	1.6	20
117	164	34	34	382	125	键 5x16	键 14x70	W45x2x21x9g	EXT21Zx2mx30Rx5f	2.5	2.5	20
160	137	34	34	396	96	键 5x16	键 14x70	W45x2x21x9g	EXT21Zx2mx30Rx5f	2.5	2.5	20

规格 size	X1、X2	A1、X3	T	T1	R	G	A、B	S	重量 weight Kg
20	M14x1.5	M12x1.5	M12x1.5	M12x1.5	M16x1.5	M14x1.5	SAE3/4" or M27x2	SAE1 1/2"	19
28	M14x1.5	M12x1.5	M12x1.5	M12x1.5	M16x1.5	M14x1.5	SAE3/4" or M27x2	SAE1 1/2"	19
40	M14x1.5	M18x1.5	M12x1.5	M18x1.5	M18x1.5	M14x1.5	SAE3/4" or M33x2	SAE2"	28
55	M14x1.5	M18x1.5	M12x1.5	M18x1.5	M18x1.5	M14x1.5	SAE3/4" or M33x2	SAE2"	28
58	M14x1.5	M18x1.5	M12x1.5	M18x1.5	M18x1.5	M14x1.5	SAE1" or M42x2	SAE2 1/2"	44
80	M14x1.5	M18x1.5	M12x1.5	M18x1.5	M18x1.5	M14x1.5	SAE1" or M42x2	SAE2 1/2"	44
78	M14x1.5	M18x1.5	M12x1.5	M18x1.5	M18x1.5	M14x1.5	SAE1" or M42x2	SAE2 1/2"	53
107	M14x1.5	M18x1.5	M12x1.5	M18x1.5	M18x1.5	M14x1.5	SAE1" or M42x2	SAE2 1/2"	53
117	M14x1.5	M20x1.5	M12x1.5	M18x1.5	M22x1.5	M14x1.5	SAE1 1/4" or M48x2	SAE3"	76
160	M14x1.5	M20x1.5	M12x1.5	M18x1.5	M22x1.5	M14x1.5	SAE1 1/4" or M48x2	SAE3"	76