

型号说明 Model Code



型号 Type

定量泵 / 马达 Fixed displacement Pump/motor A2F

规格 Size

规格 Size	排量 Displacement (Vgmin~Vgmax)
10	(9.4ml/r)
12	(11.6ml/r)
23	(22.7ml/r)
28	(28.1ml/r)
45	(44.3ml/r)
55	(54.8ml/r)
63	(63.0ml/r)
80	(80.0ml/r)
107	(107ml/r)
125	(125ml/r)
160	(160ml/r)
200	(200ml/r)
225	(225ml/r)
250	(250ml/r)
355	(355ml/r)
500	(500ml/r)

A2F	55	R	2	P	3
-----	----	---	---	---	---

后盖形式 Rear cover

后盖 Port Plate	1
后盖 Port Plate	2
后盖 Port Plate	3
后盖 Port Plate	4
后盖 Port Plate	5
后盖 Port Plate	6
后盖 Port Plate	7

轴伸 shaft End

平键 keyed shaft GB1096-79	P
花键 splines shaft DIN 5480	Z
花键 splines shaft GB 3478.1-83	S

系列 Series

系列 Series	规格 Size 10-160	1
系列 Series		2
系列 Series		3
系列 Series		4
系列 Series		5
系列 Series	规格 Size 200-500	5

旋转方向 Direction of Rotation

(从轴端看)	(Viewed on drive shaft)	
顺时针	Clock wise	R
逆时针	Anti-clock wise	L
双向	Alternating	W

(不适用于开式回路中的泵)
(not for pumps in open circuit)

Series 1-4, Size 10-160

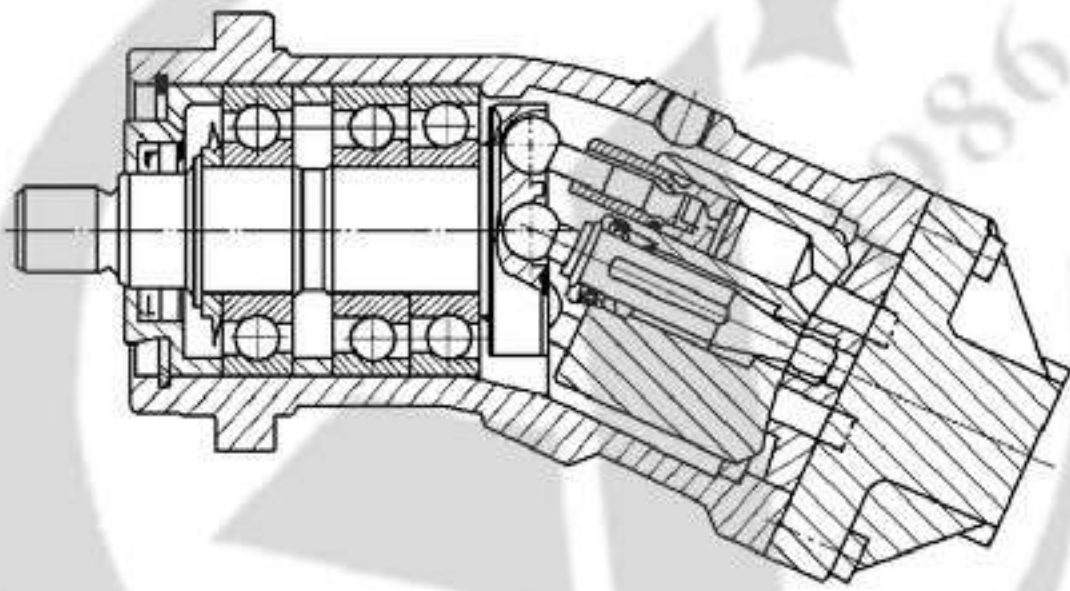

Series 5, Size 200-500

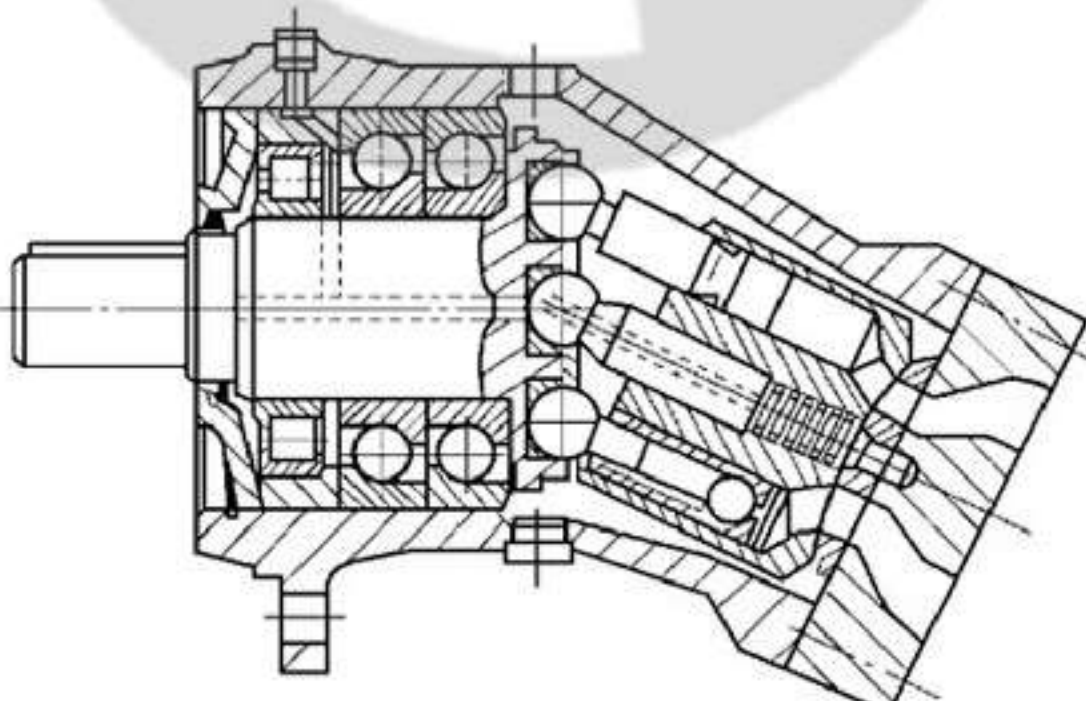

后盖形式 Rear cover:

	(规格 Size) 10~160	200~500
用于闭式回路泵工况和马达工况 Used for close system pump / motor	1. A,B 螺纹 Thread	1. A,B 法兰 Flange
	2. A,B 法兰 Flange	
	3. A,B 法兰 Flange	2. B,S 法兰 Flange
用于开式回路泵工况 Used for open system pump	4. B,S 螺纹 Thread	
	5. B,S 锥螺纹 Prick Worm	
	6. A,B 法兰 Flange	
	7. A,B 法兰 Flange	

■ 元件外形尺寸 系列1~4 规格10~160 Unit Dimensions Series 1~4 Size 10~160

系列 Series 1,3,4

后盖形式 Rear cover

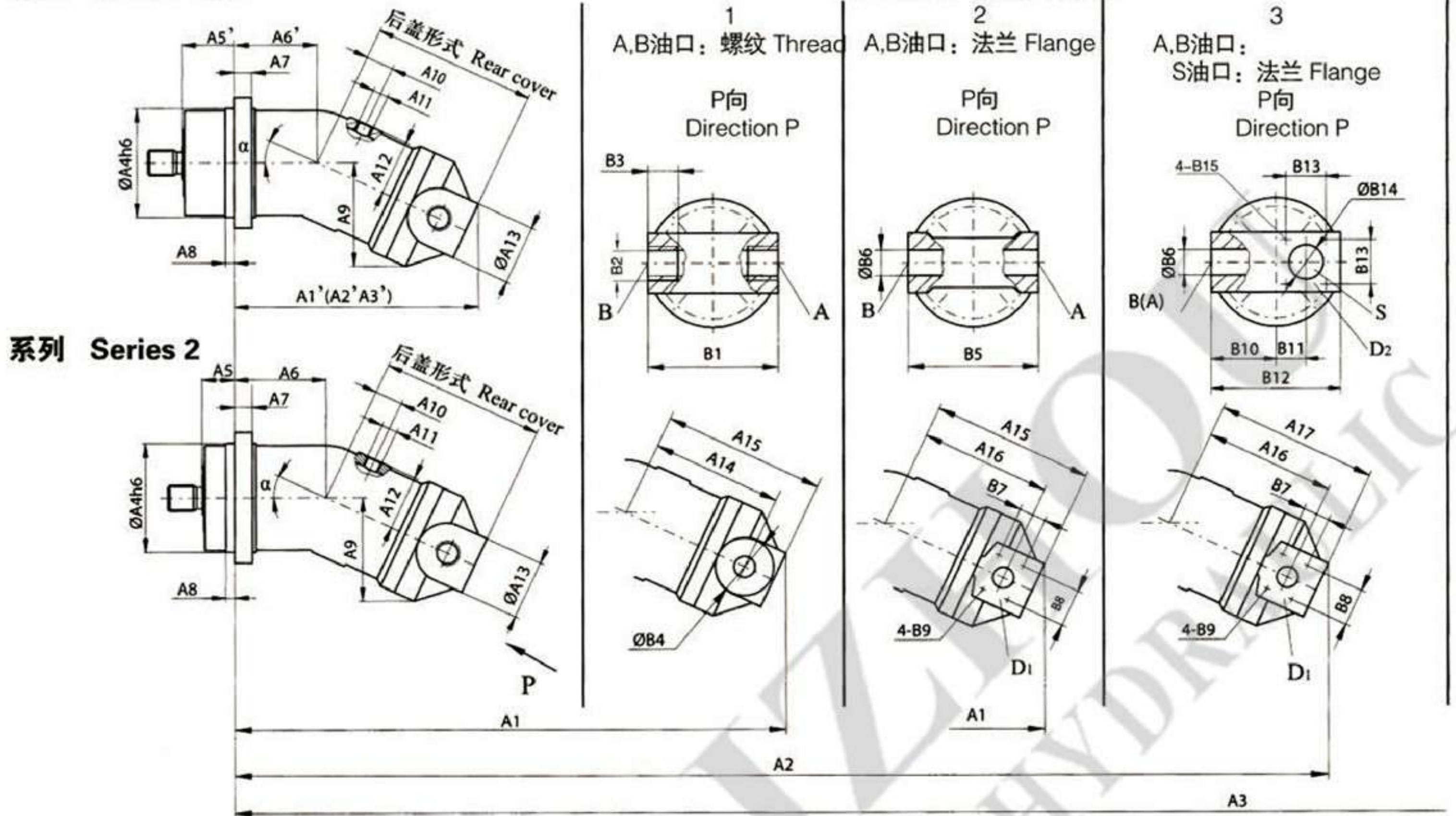

系列 Series 2

4
A,B油口: 螺纹 Thread
P向
Direction P

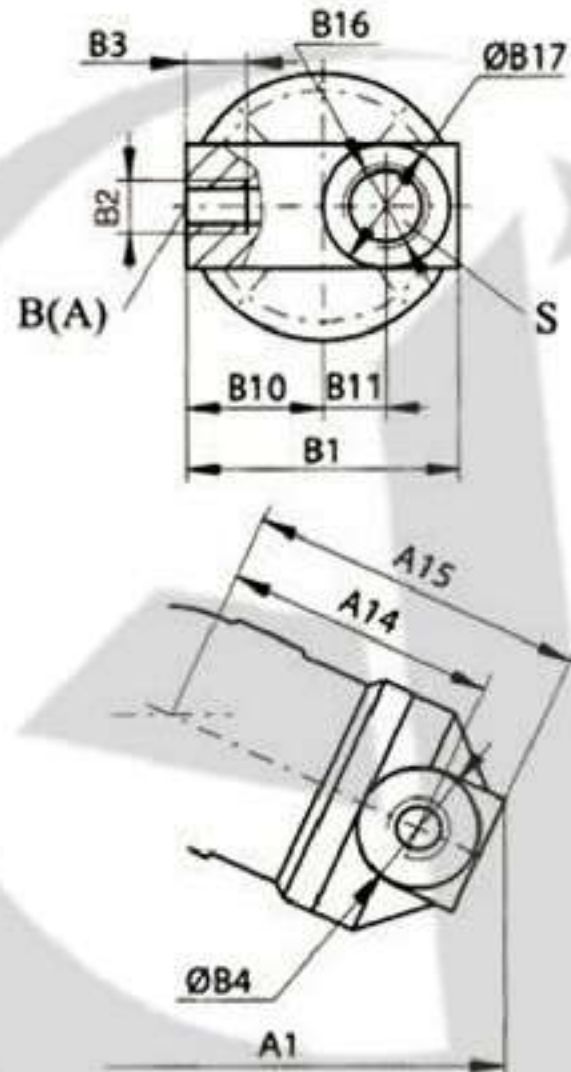

6
A,B油口: 法兰 Flange
P向
Direction P

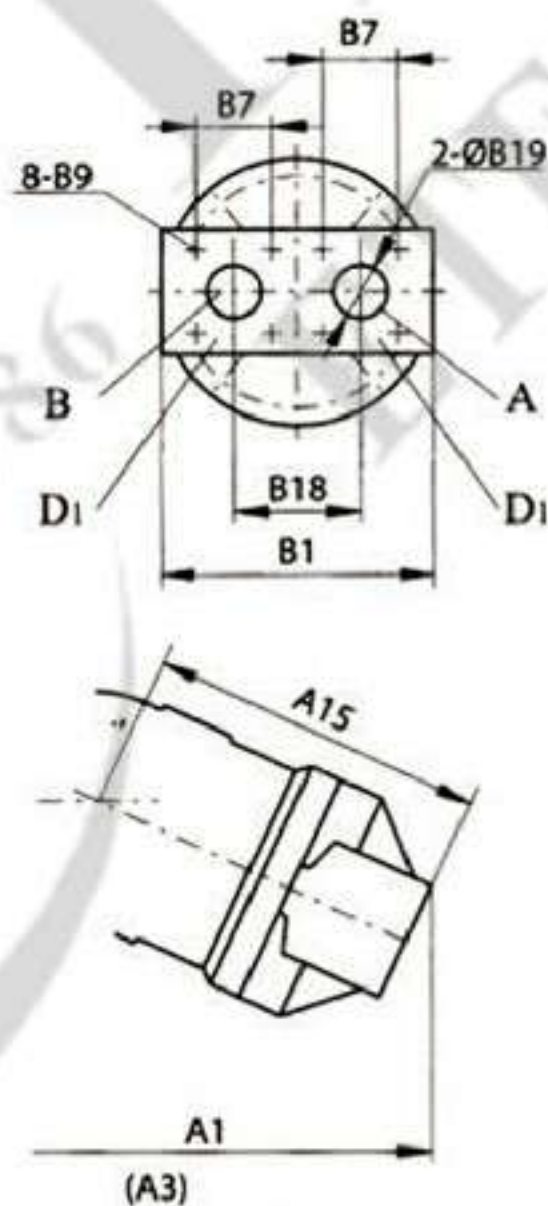

7
A,B油口: 法兰 Flange
Z向
Direction Z

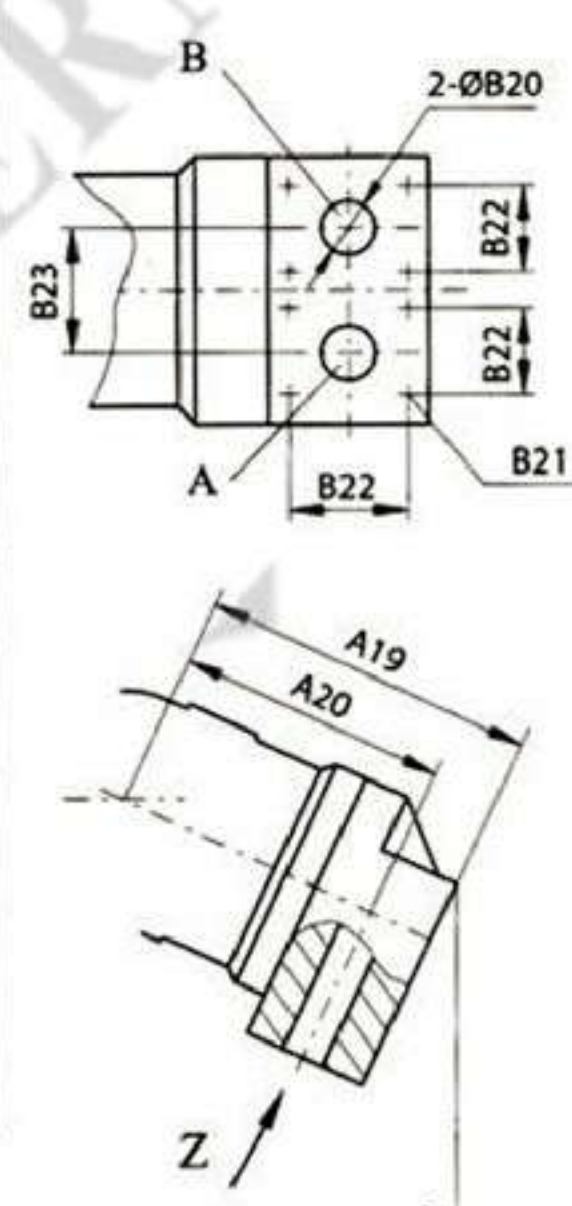

S向
Direction S

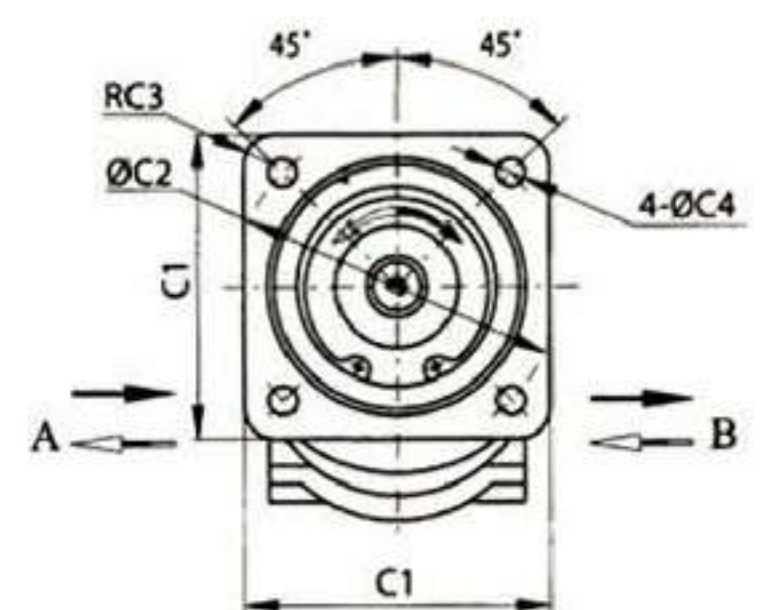

轴伸 Shaft
花键 Splined DIN5480
花键 Splined GB3478.1-83

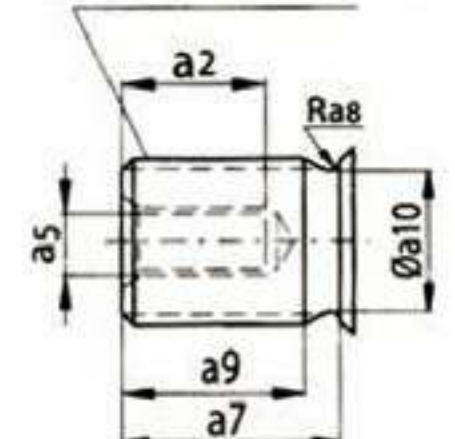

平键 Keyed shaft (GB1096-79)

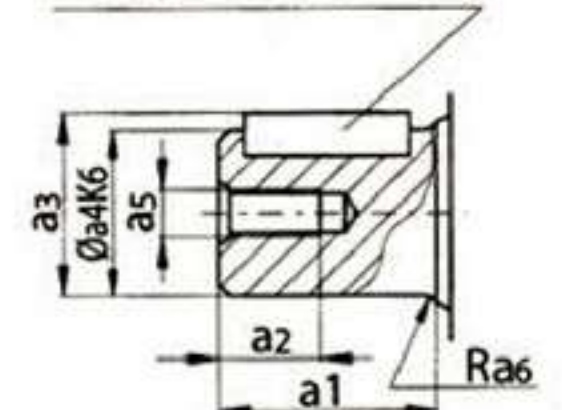

注:
1. A1、A2和A3的尺寸只适用于系列2, 对系列1,3,4的对应值由下式求出:
 $A1' = A1 - (A6 - A6')$; $A2' = A2 - (A6 - A6')$; $A3' = A3 - (A6 - A6')$ 。
除上述结构形式外, 还可以根据用户特殊需要对现有产品进行改制。

Note:
1. The dimensions of A1、A2、A3 are only valid for series 2. The parallel dimensions of the three above mentioned positions for series 1,3 and 4 can be calculated according to the follows formula: $A1' = A1 - (A6 - A6')$; $A2' = A2 - (A6 - A6')$; $A3' = A3 - (A6 - A6')$ 。
2. Besides above mentioned constructs, we can adjust the design of the present product according to the customers' special needs.

■ A2F定量柱塞泵/马达(1~5系列) A2F Fixed Displacement pump/motor(1~5 Series)

元件外形尺寸 系列1~4 规格10~160 Unit Dimension Series 1~4 Size 10~160

规格 α20°	Size α25°	系列 Series	后盖形式 Rear cover	A1		A2		A3		A4	A5	A6	A5'	A6'	A7	A8	A9	
				α20°	α25°	α20°	α25°	α20°	α25°								α20°	α25°
10	12	2,4	1,4	174	172	-	-	-	-	80	20	62	40	42	12.5	8	69	75
23	28	2,3	1,2,4	223	218	-	-	-	-	100	25	75	50	50	16	8	88	95
45	55	1,2	1,2,3,6	292	289	286	284	-	-	125	32	108	63	77	20	10	110	118
63	80	1,2	1,2,3	350	348	345	342	-	-	140	32	137	83	86	23	10	126	140
87	107	1,2	1,2,3,7	360	356	353	348	358	353	160	40	130	80	90	25	12	138	149
125	160	2	1,2,3,7	422	417	417	410	408	420	180	40	156	-	-	28	10	159	173.5

规格 α20°	Size α25°	A10	A11	A12	A13	A14	A15	A16	A17	A18		A19	A20	B1	B2	B3	B4
										α20°	α25°						
10	12	14	M12×1.5	40	-	90	112	-	-	-	-	-	-	89	M22×1.5	14	40
23	28	25	M16×1.5	50	-	118	145	118	-	-	-	-	-	106	M27×2	16	47
45	55	31.5	M18×1.5	63	-	151	183	151	178	-	-	-	-	132	M33×2	18	53
63	80	36	M18×1.5	77	-	174	213	174	208	-	-	-	-	156	M42×2	20	63
87	107	40	M18×1.5	80	-	190	230	190	225	185	200	230	195	165	M42×2	20	66
125	160	45	M22×1.5	93	-	212	262	212	257	204	220	252	212	195	M48×2	22	70

规格 α20°	Size α25°	B5	B6	B7	B8	B9	深		B10	B11	B12	B13	B14	B15	深		B17	B18	B19	B20
							Deep	深							Deep	深				
10	12	-	-	-	-	-	-	-	44.5	18	-	-	-	-	M33×2	18	42	-	-	-
23	28	120	13	18.2	40.5	M8	15	53	25	-	-	-	-	M42×2	20	48	-	-	-	
45	55	126	19	23.8	50.8	M10	15	63	29	129	48	50	M10	13	-	-	-	67	20	-
63	80	150	25	27.8	57.1	M12	15	75	35.5	153	60	56	M12	15	-	-	-	-	-	
87	107	160	25	27.8	57.1	M12	17	80	35.5	162.5	60	56	M12	18	-	-	-	-	25	
125	160	190	32	31.8	66.7	M14	19	95	42.2	192.5	75	70	M16	20	-	-	-	-	39	

规格 α20°	Size α25°	深		B23	C1	C2	C3	C4	a1	a2	a3	a4	a5	a6	a7	a8	a9	a10	
		B21	Deep																
10	12	-	-	-	95	100	10	9	40	16	22.5	20	M6	0.8	34	2	22	16.7	
23	28	-	-	-	118	125	12	11	50	19	27.9	25	M8	0.8	43	1.2	28	21.5	
45	55	-	-	-	150	160	16	13.5	60	28	33	30	M12	1.5	35	1.5	28	25	
63	80	-	-	-	165	180	16	13.5	70	28	38	35	M12	1.6	40	1.5	33	30	
87	107	M12	25	50	78	190	200	20	17.5	80	28	43	40	M12	1.6	45	2	37.5	35
125	160	M12	25	50	78	210	224	20	17.5	90	36	48.5	45	M16	2.5	50	2.5	43	40

规格 α20°	Size α25°	SEA法兰 SEAFlang		平键盘Paralled	花键Splined Shaft	花键Splined Shaft	重量 Weight (kg)
		D1	D2	BG1096-79	DIN5480	GB3478-83	
10	12	-	-	键Key6×32	W20×1.25×14×9g	EXT14Z×1.25×30R×5f	5
23	28	1/2"	1/2"	键Key8×40	W25×1.25×18×9g	EXT18Z×1.25×30R×5f	12
45	55	3/4"	13/4"	键Key8×50	W30×2×14×9g	EXT14Z×2m×30R×5f	23
63	80	1"	2"	键Key10×56	W35×2×16×9g	EXT16Z×2m×30R×5f	33
87	107	1"	2"	键Key12×63	W40×2×18×9g	EXT18Z×2m×30R×5f	44
125	160	1 1/4"	2 3/4"	键Key14×70	W45×2×21×9g	EXT21Z×2m×30R×5f	63

■ 元件外形尺寸 Unit Dimension Series 5

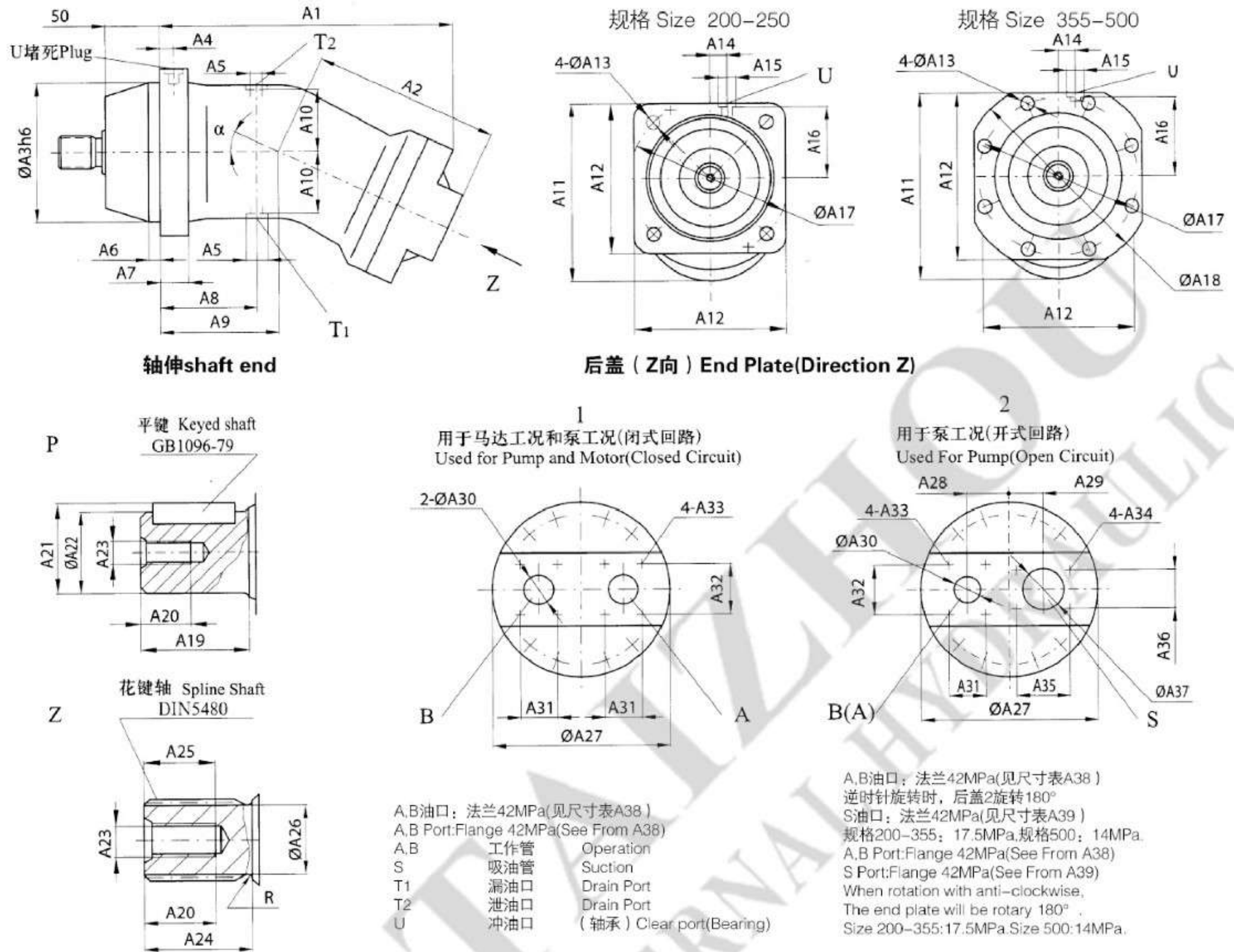

■ 系列5 规格200-500元件外形尺寸表 Series 5 Size 200-500 Table of Unit Dimension

规格 Size	α	A1	A2	A3	A4	A5	A6	A7	A8	A9	A10	A11	A12	A13	A14	A15
200	21°	368	232	224	13	M22 × 1.5	9	25	120	134	107	300	252	22	70	M14 × 1.5
250	26.5°	370	232	224	13	M22 × 1.5	9	25	120	134	107	314	252	22	70	M14 × 1.5
355	26.5°	422	260	280	14	M33 × 2	15	28	142	160	128	380	335	18	35	M14 × 1.5
500	26.5°	462	283	315	15	M33 × 2	15	30	155	175	142	420	375	22	35	M18 × 1.5

规格 Size	A16	A17	A18	A19	A20	A21	A22	A23	A24	A25	A26	A27	A28	A29	A30	A31	A32	A33
200	122	280	/	82	36	53.5	50k6	M16	58	47	45	216	55	45	32	31.8	66.7	M14
250	122	280	/	82	36	53.5	50k6	M16	58	47	45	216	55	45	32	31.8	66.7	M14
355	166	320	360	105	42	64	60m6	M20	82	69	55	245	60	50	40	36.6	79.4	M16
500	180	360	400	105	42	74.5	70m6	M20	82	67	62.5	270	65	55	40	36.6	79.4	M16

规格 Size	Deep	A34	Deep	R	A35	A36	A37	A38	A39	平键 Paralled BG1096-79	花键 Spline DIN5480	重量 (kg) Weight
200	22	M12	18	1.2	88.9	50.8	63	1 1/4"	2 1/2"	键 Key 14 × 80	W50 × 2 × 24 × 9g	88
250	22	M12	18	1.2	88.9	50.8	63	1 1/4"	2 1/2"	键 Key 14 × 80	W50 × 2 × 24 × 9g	88
355	24	M12	18	1.6	88.9	50.8	63	1 1/2"	2 1/2"	键 Key 18 × 100	W60 × 2 × 28 × 9g	138
500	24	M16	24	1.6	106.4	62	75	1 1/2"	3"	键 Key 20 × 100	W70 × 3 × 22 × 9g	185